



DONIT[®]
A perfect fit

Quality In Gasket and Sealing Technology





Industrial Gaskets is 100% Australian Owned and Operated.

Industrial Gaskets have been supplying High Quality Sealing products to an extensive variety of industries Australia wide at competitive prices for over 35 years.

We aim to make dealing with Industrial Gaskets as easy as possible. We have a team of highly experienced personnel who are able to offer advice on applications and help you with solutions.

As a commitment to providing quality service and products, Industrial Gaskets is a Quality Endorsed and Certified company to the ISO9001 system.

At Industrial Gaskets we are Proud of our Reputation for Service, Cost Effective Problem Solving, Well Recognized Quality and Pricing.

Our friendly, efficient sales team are ready to accept your orders, deal with your technical queries and assist with other problems or challenges that you may have with your application.

Please also visit our website at www.industrialgaskets.com.au for further technical information on our extensive product range.

Sales Enquiries Email: sales@industrialgaskets.com.au

Or call (08) 8276 4140

Unit 2 / 4 Iris Street, Melrose Park, South Australia

Contents



Company Profile	2
Capabilities	5
Spiral Wound Gaskets	
Styles & Metal & Filler Material Limits	6 - 7
Heat Exchanger Gaskets	8
Metal Jacketed Gaskets	9
Kamprofile Gaskets	10
Ring Joint Gaskets “ RTJ ’ s ”	
Introduction	11
Sizes / Styles	12
Specialty Coatings & Materials	13 - 14
Gasket Sheeting	
Compressed Fibre	15 - 17
High Temperature	18 - 19
Modified PTFE / PTFE	20 - 21
Cork	22
Other Gasket Materials	23
Engineering & Thermal Plastics	24 - 25
Rubber Sheet and Elastomers	26
Silicone	27
Viton	28
Neoprene	29
EPDM	30
Nitrile	31
Natural	32
Natural Insertion	33 - 34
FRAS	35
Lining / Wear Rubbers	36 - 37
Rubber Cord & Strips	38
Sponge Rubber & Foam	39

Industrial Gaskets reserves the right to change or modify any of its products, no liability is entered into or given on any of the data provided. Consultation of a technician should be sought if in any doubt .

Contents Continued



Valve & Pump Packing	41 - 43
Installation Instructions	44
Sundry Packing Items	45
PTFE Tape & Cord	46
Flange & Bolt Insulation	
Flange Insulation Kits	47
Bolt Insulators - Insulating Sleeves	48 - 49
Bolt Insulators — Insulating Washers	50
Critical Service Flange Isolation	51 - 52
Flange Protection Products	53 - 58
Fibreglass Products	59
Ceramic Products	60
Expansion Joints - Metallic & Non Metallic	61
Adhesives & Sealants	62
Pipe Couplings	
Straub® Couplings	63
Uni® Couplings	64
Torque Saver Gaskets	65
Information	66 - 72



Industrial Gaskets reserves the right to change or modify any of its products, no liability is entered into or given on any of the data provided. Consultation of a technician should be sought if in any doubt .

Capabilities



Industrial Gaskets capabilities are infinite.

Extensive stock of specialty steel gaskets including Spiral Wound Gaskets and Ring Type Joint Gaskets (RTJ) are held at our manufacturing facility in South Australia and supplied Australia wide.

Gasket materials for all sealing requirements including any Elastomer/rubber through to High Temp, Compressed Fibre, Graphite, Potable Water Approved Sheeting, Engineered Plastics and Specialty PTFE Sheeting.

Inhouse manufacture of Bolt isolation products and flange isolation kits .



With the leading edge technology of our Digital Gasket cutters there are no limitations to the size or style of gasket that can be produced. Laser cutters can leave burned edges, our latest technology digital cutters leave smooth clean edges on gaskets. Waterjet cutting is a messy, longer and more expensive way to cut materials.

With our CNC Digital Gasket Cutters Industrial Gaskets is able to offer a quality, cost effective part with a fast turnaround and pinpoint accuracy.

Abundant pre-cut Gasket stocks held in standard pipe configurations and commonly sought after materials.

Minimal lead times for Specialty Gaskets
Same Day and
Time Crucial Supply Available



Please contact our sales team for further information and technical advice.

Spiral Wound Gasket Styles

“SWG” or “SPWD”



IG Style 234 or “CG”

An integral centering ring (or guide ring) assures fast, accurate centering of the gasket on the flange.
It also acts as a compression limiter to prevent over compression of the winding (or sealing face) of the gasket.

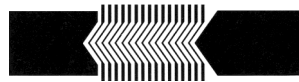

IG Style 1234 or “CGIR”

This style has an outer ring, windings (sealing element) and inner ring.
Recommended for higher pressure applications and where specifying PTFE filler material.
Inner Ring also acts as a compression limiter, prevents inward buckling at the windings and provides protection of the windings from process media.



IG Style 24 or “R”

Windings (or sealing element) only. This style is a V Shaped metal strip wound with a filler.
The filler is commonly Graphite.
Typically used in tongue and groove, male-female, valve bonnet and OEM applications.



IG Style 123 or “RIR”

This style is a V Shaped metal strip wound with a filler
Windings (or sealing element) with an Inner Ring.
Typically used to protect windings (sealing face) against media and pressure.

Please contact our sales team for further information and technical advice.

Metal & Filler Material Limits For Spiral Wound Gaskets



Temperature Limits for Common Materials

Material	Lower Limit		Upper Limit		Abbreviation	Guide Ring Colour Code
	°F	°C	°F	°C		
304 Stainless Steel	-320	-195	1400	760	304	Yellow
316L Stainless Steel	-150	-100	1400	760	316L	Green
321 Stainless Steel	-320	-195	1400	760	321	Turquoise
347 Stainless Steel	-320	-195	1700	925	347	Blue
Carbon Steel	-40	-40	1000	540	CRS	Silver
Alloy 20 (20Cb-3)	-300	-185	1400	760	A-20	Black
Hastelloy C276	-300	-185	2000	1090	HAST C	Beige
Hastelloy B2	-300	-185	2000	1090	HAST B	Brown
Incoloy 800	-150	-100	1600	870	IN800	White
Inconel 600	-150	-100	2000	1090	INC600	Gold
Inconel 750	-150	-100	2000	1090	INX	No Colour
Monel 400	-200	-150	1500	820	MON	Orange
Nickel 200	-320	-195	1400	760	NI	Red
Titanium	-320	-195	2000	1090	TI	Purple

Temperature Limits for Filler Materials

Material	Lower Limit		Upper Limit		Abbreviation	Guide Ring Colour Code
	°F	°C	°F	°C		
Ceramic	-350	-212	2000	1090	CER	Light Green
Flexible Graphite	-350	-212	950	510	FG	Grey
PTFE	-400	-240	500	230	PTFE	White
Mica Graphite	-350	-212	600	345	VC	Pink

Please contact our sales team for further information and technical advice.

Heat exchanger gasket is a term that has been given to gaskets used in heat exchangers. Also commonly known as Metal Jacket Gaskets, the structure of the gasket or its type varies according to the operating conditions of the exchangers.

These gaskets come in a wide spectrum of types including single or double-jacketed, corrugated, plain metal, soft and many others. The sealing filler provides resilience while the metal jacket offers good sealing properties and protects the filler against pressure conditions, corrosion and temperature fluctuations.

Heat exchanger gaskets are manufactured using graphite, compressed fiber sheet or millboard as a soft filler, protected by an outer double jacket in various metals such as soft iron, copper or stainless steel.

These gaskets can be made with integral or welded pass bars.

They are most commonly used in heat exchangers, autoclaves, vessels, pumps and valves.

Double Jacketed Corrugated

This gasket employs a corrugated jacket to increase resilience. Suited for circular and non – circular applications in widths of 3/8 ” and wider. It is an improvement over the standard double jacketed gasket. If slight leakage should occur across the primary seal at the inner edge of the gasket, the concentric corrugations act as a labyrinth seal.

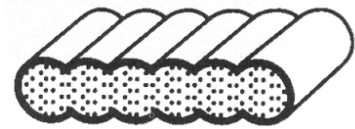

MC—1

Corrugated Solid Metal

A plain all metal corrugated gasket for use in low pressure applications that require a thin line contact because of space or weight limitations.

Corrugated gaskets are a versatile sealing element where the available bolt loads are low. Depending on the materials and the construction these gaskets can be very



MC—2

Single Jacketed Overlap

Constructions of this gasket offers more filler protection than the standard single jacketed design. It is especially useful for applications where the radial dimensions do not allow space for a double jacketed gaskets.

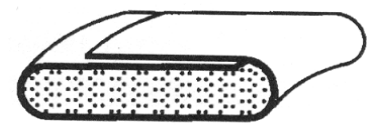

MC—3

Double Jacketed

The double jacketed gasket has good compressibility and resilience and is the most popular clad gasket manufactured.

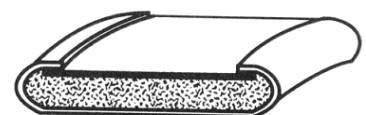

MC—4

Shown above are just 4 of the most popular cross sections of gasket styles. Many more are available as a large range of materials and fillers. Please contact our sales team for further configurations

Please contact our sales team for further information and technical advice.

Metal Jacketed Gaskets



ADVANTAGES

- ⇒ Available in wide range of materials, since they are all custom made. There are few limitations regarding size and shape.
- ⇒ The metal jacket provides mechanical strength to contain the filler and improves chemical resistance.
- ⇒ Unique construction provides stability and ensures trouble-free handling and installation.

SHAPE AND CONSTRUCTION These gaskets are used in shell and tube type heat exchangers. They can be manufactured in very different sizes, shapes, with or without bars. The primary seal is at the inner diameter of the gasket, the outer gasket diameter acts as a secondary seal. The bars seal between the heat exchangers passages. The heat exchanger gaskets are produced in several types to meet the most demanding applications. Gaskets for heat exchangers can be manufactured in metal or alloy with a thickness 0.4 mm featuring a soft core inside a metallic jacket.

Gaskets with integrated bars traditionally double-jacketed gaskets for heat exchangers are manufactured with integrated bars. There is a radius between the bars and an internal diameter of the gaskets. The values of the corresponding radius for the most commonly used metals and alloys are shown in the following table. If a radius is less than R_{min} , the material can crack, reducing the sealing properties of the gaskets.

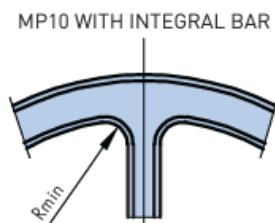

GASKET MATERIALS and R_{min}	
Gasket material	R_{min}
Copper	8 mm
Soft iron	8 mm
Carbon steel	8 mm
Brass, Monel	10 mm
Stainless steel	10 mm

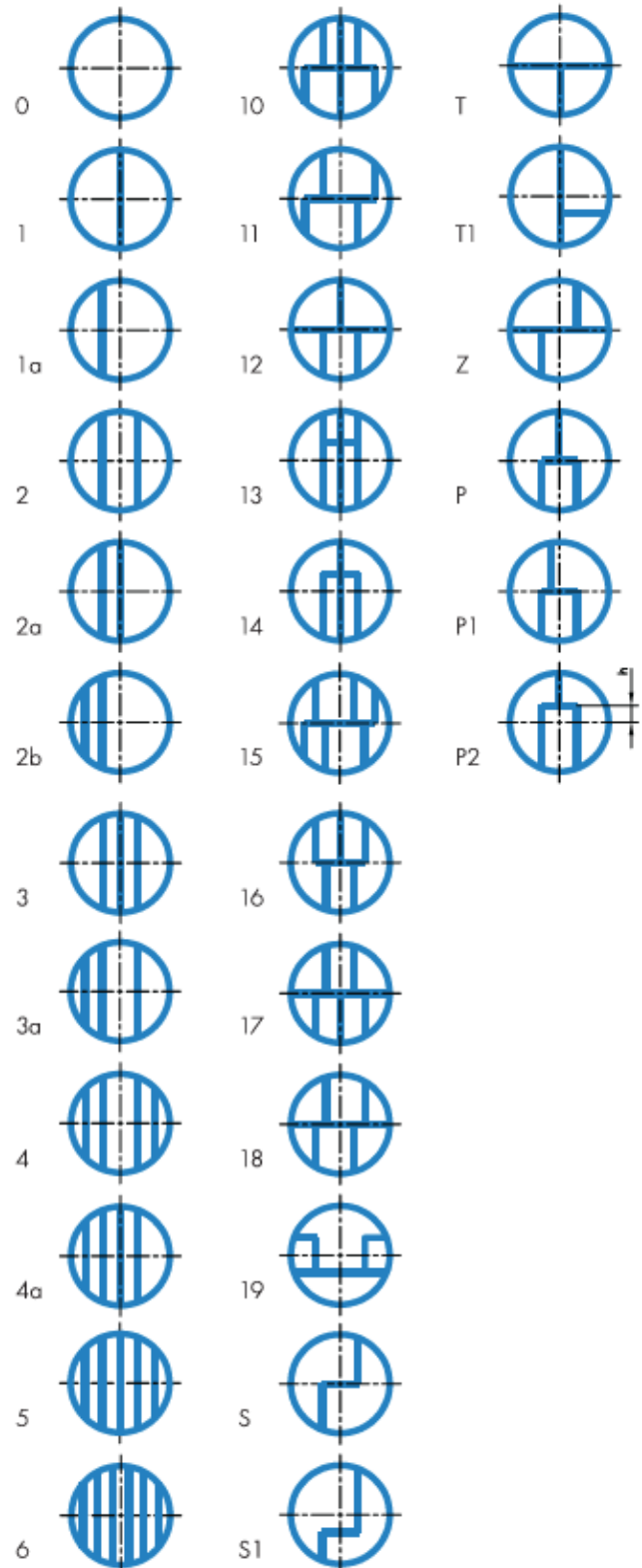

Please contact our sales team for further information and technical advice.

Kamprofile gaskets offer a safe, effective seal under the most exacting conditions on both standard pipework and specialist applications. It offers excellent flexibility and recovery characteristics, allowing seal integrity under pressure and temperature fluctuations, temperature differential across the flange face, flange rotation, bolt stress relaxation and creep.

The Kamprofile is comprised of concentrically serrated solid metal core with a soft, conformable sealing material bonded to each face. The soft facing material provides low stress gasket seating, while the serrated geometry of the metal core enhances sealing performance by inducing stress concentrations on the sealing surfaces. The serrations minimize lateral movement of the facing material, while the metal core provides rigidity and blowout resistance.

Key Benefits include:

- ⇒ Gasket will not damage the flange surface and can be easily removed.
- ⇒ Reduced maintenance costs due to longevity of gasket and increase reliability.
- ⇒ Seals damaged and imperfect flanges.
- ⇒ Handles pressures from Vacuum to Class 2500
- ⇒ Accommodates all standard ASME flanges as well as non standard sealing faces.
- ⇒ Withstands temperatures from cryogenic to 1090°C (depending on sealing material or metal)

Serrated Solid Metal Core

- Solid Metal core resists cold flow, over compression and blow out.
- Facilitates handling and installation.
- Available in wide variety of materials including Stainless Steel, Titanium, Soft Iron, Monel, Incolloy & Hastalloy.
- Rigid core provides superior stability even in larger sizes.

Deformable, Softer Sealing Material

- Seals under low stress, ideal for delicate flanges.
- Withstands extreme fluctuations in temperatures & pressures.
- Available in wide variety of materials including Graphite, Mica, PTFE (Teflon), Compressed Fibre or Metal (eg Aluminium).
- Under compression, fills seating surface imperfections to form a tight, metal to metal seal.

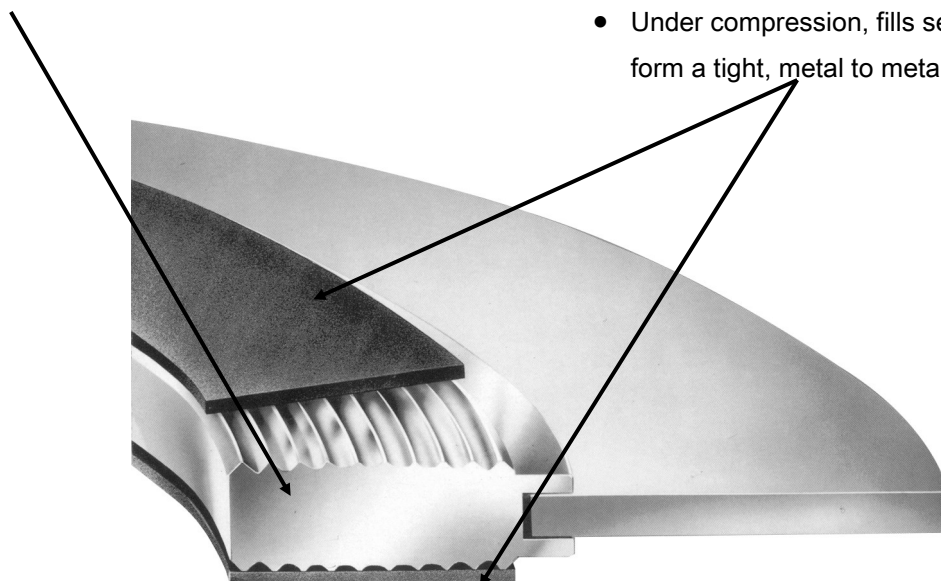

Please contact our sales team for further information and technical advice.

Ring Joint Gaskets “RTJ’s”

Introduction



Ring Type Joint Gaskets or “RTJ ’s as they are commonly known are metallic sealing rings suitable for high temperature and pressure applications and are fitted in ring groove type flange applications. They are widely used in the oil/gas (onshore & offshore) , petrochemical industries and in valve and pipework. Choice of material may be determined to suit higher temperatures and aggressive media. They comply with ASME B16.20 standards and API 6A specification. Industrial Gaskets only supplies Ring Type Joint Gaskets that are API approved and Certified.

Ring joint gaskets are commonly made out of the following materials:

Soft Iron / Low Carbon Steel / Stainless Steel / Monel® / Inconel® / Incoloy® / Hastelloy® / Duplex

The gasket material should be selected to suit the service conditions. It is always recommended that the gasket material be softer than the mating flanges.

Each Ring Type Joint is identified by low stress stamping with style, ring number, API license number, material reference, month and year of manufacture and unique Industrial Gaskets material identification number.

In accordance with API Specifications, soft iron and low carbon steel Ring Type Joints are protected with electroplated zinc to a maximum thickness of 8µm. Alternative material coatings can be supplied on request.

Both oval and octagonal configurations are interchangeable on the modern octagonal type grooved flanges.

Cross Section / Styles

- **R** Oval or octagonal style of gasket
- **RX** Self-energizing style of gasket
- **BX** Used in API spec 6A flanges that have ring grooves machined into them to accept this style of gasket
- **SRX** Similar to the RX style gasket with special vent holes to allow water to escape in subsea applications
- **SBX** Similar to the BX style gasket with special vent holes to allow water to escape in subsea applications
- **Combo** Consists of two different sizes having the same pitch. Used where mating flanges have different groove dimensions

[Sizing & Configuration Charts are available in our RTJ Brochure](#)

Please contact our sales team for further information and technical advice.

Ring Joint Gaskets "RTJ's"

Sizes / Styles



R-Type ring gasket can be ordered to two different profiles, oval or octagonal in cross-sections. Both types have identical pitch diameter as the flange groove they correspond to. These gaskets are used in pressures up to 5,000 PSI. The octagonal type has a higher sealing coefficient than the oval, therefore being the better gasket of the two. The oval type is the only gasket that will fit a bottom radius groove. Newer style flanges with flat bottom v-grooves will accept either style.



RX gaskets are designed for pressures up to 10,000 PSI. These gaskets are interchangeable with r-oval or r-octagonal rings used on API 6B flanges. RX types of gaskets are more costly than your standard oval or octagonal rings, therefore not as popular. RX type gaskets perform excellent in 6B flanged blowout preventer stacks, which requires the additional mass of the RX gasket to support the higher pressures with higher vibrations and heavier weights of these units.

Although similar in style to the octagonal gaskets, the **BX Series** can only be used with 6BX flanges and 16BX hubs. BX-Gaskets have been designed for higher-pressure ratings upto 20,000 PSI. Pitch diameters on BX gaskets are slightly larger than the pitch diameter of the flange. This forces the gasket to initially seal on its outside angles and secondly seal with its inside angles as the flange is bolted down to respective torque settings.



The American Petroleum has standardized the underwater utilization of ring gaskets with the **SRX and the SBX series** rings. There is no dimensional difference between the standard RX and SRX or the BX and SBX. They will fit into their appropriate flange designated numbers. The "S" prefix identifies a gasket as having intersecting vent holes, allowing a pressure less metal-to-metal initial contact between the gasket and flange groove, while made up underwater. For pressure class ratings on these gaskets refer back to their non "S" type standard gasket classification chart for the [RX](#) and [BX-Series](#).

Sizing & Configuration Charts are available in our RTJ Brochure

Please contact our sales team for further information and technical advice.

Ring Joint Gaskets “RTJ’s” Specialty Coatings



RUBBER COATED RING TYPE JOINTS

This is a Ring Type Joint totally enclosed in a Nitrile rubber coating. The RTJ material is usually soft iron or low carbon steel. This type of gasket has three main functions:

- It is used in pressure testing to minimise damage to flanges.
- The rubber contact points provide additional seals while protecting the flange surfaces.
- It provides increased assurance against corrosion, which can occur between conventional Ring Type Joints and the engaged surfaces of the groove.



PTFE COATED RING TYPE JOINTS

This is a Ring Type Joint totally enclosed in a PTFE coating. The RTJ material is usually soft iron or low carbon steel. This type of gasket is predominately used in aggressive media applications. Coating can be in various colours eg. blue or green for ease of identification on site.



RING TYPE JOINTS WITH PTFE INSERTS

Ring Type Joints can also be supplied with PTFE inserts, in order to reduce turbulent flow and eliminate gasket/flange erosion. The insert is specially designed with radially drilled pressure passage holes so that the self energising performance of the Ring Joint is not impaired.

The insert is located between the inside diameter of the Ring Type Joint and the bore of the flange. On assembly, the insert is completely trapped between the make up of the flanges, filling the annular space between the flange bore and



Sizing & Configuration Charts are available in our RTJ Brochure

Please contact our sales team for further information and technical advice.

Industrial Gaskets — sales@industrialgaskets.com.au

Technical

Ring Type Joint Materials



Ring Type Joint Materials

Gasket material should be selected to suit the service conditions. It is always recommended that the gasket material be softer than the mating flanges.

In accordance with API Specifications, Soft Iron and Low Carbon Steel Ring Type Joints are protected with electroplated zinc to a maximum thickness of 8µm. Alternative material coatings can be supplied on request.

[Sizing & Configuration Charts are available in our RTJ Brochure](#)

MATERIAL	UNS NUMBER	MAXIMUM HARDNESS		IDENTIFICATION (Stamped on Ring)
		BRINELL*	ROCKWELL B †	
Soft Iron	-	90	56	D
Low Carbon Steel	-	120	68	S
4-6% Chrome 1/2% Moly	K42544	130	72	F5
Type 304 Stainless Steel	S30400	160	83	S304
Type 316 Stainless Steel	S31600	160	83	S316
Type 347 Stainless Steel	S34700	160	83	S347
Type 410 Stainless Steel	S41000	170	86	S410
Titanium Grade 2	R50400	-		
Alloy 600	N06600	200		
Alloy 625	N06625	200		
Alloy 800	N08800	200		
Alloy 825	N08825	150		
Hastelloy	N10001	200		
Alloy C276	N10276	200		
SMO 254	S32154	180		
Zeron 100	-	200		
Super Duplex	S31803	-		

* Measured with 3000 Kg load except soft iron which is measured with 500 Kg load

† Measured with 100 Kg load and 1/16 inch diameter ball

Please contact our sales team for further information and technical advice.

Gasket Sheeting - Compressed Fibre



Compressed Fibre Materials

Industrial Gaskets can offer an extensive range of Gasket Sheeting to suit your specific requirements. From basic oil jointing material and compressed fibre sheeting through to Graphite reinforced and High Temperature sheeting. Industrial Gaskets has an extensive range of gasket materials that will conform to your specifications. Some of our most popular sheeting products are shown below. Industrial Gaskets is proud to be an Authorised Distributor of the Tesnit® range of gasket materials. Through this agreement Industrial Gaskets can offer Quality gasket sheet with an extensive range of approvals and international endorsements.



TESNIT® BA-U

TESNIT® BA-U is very applicable on aramid fibres based gasketing material and high resistant NBR - nitrile butadiene rubber. Material has excellent chemical resistance, good mechanical and thermal properties. TSNIT® BA-U has application in many different industries: Food industry, Gas supply, Potable water supply (Approved to AS/NZ4020), Compressors and many more.

TESNIT® BAGL

TESNIT BAGL 3000 is a supreme fibre gasket material produced from a combination of aramid and glass fibres, specially selected fillers and elastomeric binders. With a well considered selection of all ingredients the material is free of harmful nitrosamines (certified by MRPRA) and fibres which are hazardous to human health. Its carefully balanced composition provides exceptional thermal stability and torque retention when applied in flanged joints.



TESNIT® BA-C

TESNIT® BA-C is specially developed soft gasket material for the chemical industry. It is a sealing material based on aramid fibres and CSM rubber. The material has very good resistance to acids and alkaline media. It is also very convenient for the different aggressive media. TSNIT® BA-C finds the application in all places where the chemical resistance is the most demanding factor. Gasket material with very good resistance to acids and alkaline media.

Please contact our sales team for further information and technical advice.

Gasket Sheeting - Compressed Fibre Continued



TESNIT® BA-N

TESNIT® BA-N consists of aramid fibres and CR Chloroprene rubber, so the material is specially suitable for the different media in the refrigeration industry. TASNIT® BA-N has in addition very good mechanical properties and thermal resistance which in combination with good general chemical resistance makes the material TASNIT® BA-N also very appropriate for the general application.

A gasket material with



TESNIT® BA-CF

TESNIT® BA-CF is a high grade soft gasketing material based on Carbon fibres and bonded with NBR. Material has excellent resistance to steam and strong alkaline media. It is widely used in chemical and petrochemical industry. Gasket material with excellent resistance against steam and strong alkalis. Material also complies with the requirements of BS 7531 Grade X. Specially designed gasketing material TASNIT® BA-CF is the answer to the growing demands many of aggressive chemicals.

TESNIT® BA-SOFT

TESNIT® BA-SOFT gasket material has been specially developed for demanding applications where only low bolt loads are permissible and flange irregularities need to be compensated. It offers high compressibility and increased recovery in addition to improved mechanical and thermal performances. It can be used for sealing mineral oils, fuels, lubricants, refrigerants, steam, air, and many other media.



TESNIT® BA-R

TESNIT® BA-R has very good mechanical properties (resistance to high internal and surface pressure). TASNIT® BA-R is designed for the automotive and engine-building industries.



For a more comprehensive range of sheet gasket materials please contact us

All of Industrial Gaskets' sheeting material is available in sheet form, cut to size or to suit your design specifications

Please contact our sales team for further information and technical advice.

Gasket Sheeting - Compressed Fibre Continued



DONIFLEX® G-U

DONIFLEX® G-U is devoid of any organic solvent, this graphite-based composite allaying aramid and special functional inorganics, is advanced heavy-duty material. It displays excellent physicochemical properties (thermal, chemical, stress resistance, etc.) with high compressibility and flexibility enabling it to conform to uneven surfaces.

Steam supply, heating systems, and chemical industry are amongst its well-suited application. The version with a metal insert withstands higher pressures.

Also, fitted with a highly performant anti-stick, gasket replacement is quite effortless following prolonged elevated temperature service

DONIFLEX® G-U is a flexible gasket material range made from graphite, aramid fibers, specially selected fillers, and a vulcanized rubber binder. Having excellent thermal properties and good chemical resistance to various media, these materials are suitable for a wide range of applications.

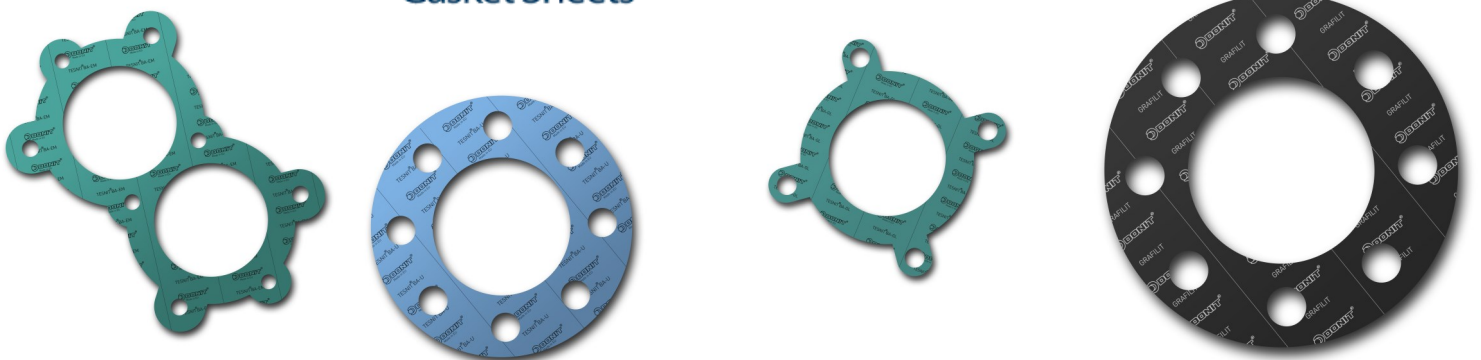

For a more comprehensive range of sheet gasket materials please contact us

All of Industrial Gaskets' sheeting material is available in sheet form, cut to size or to suit your design specifications

Please contact our sales team for further information and technical advice.

Gasket Sheet - High Temperature



GRAFILIT SL

GRAFILIT® SL is an expanded graphite based material with stainless steel foil insert, thus facilitating its handling and enhances the surface load.

GRAFILIT® SL has excellent chemical and thermal resistance. Its high creep resistance and high compressibility make it suitable for highly demanding conditions in the chemical and petrochemical industries. Expanded natural graphite (>99% graphite purity) High resistance to media, particularly corrosive substances and chemicals. Excellent for steam applications.

GRAFILIT SP

GRAFILIT® SP is an expanded graphite-based material with a tanged stainless steel insert, thus enhancing the surface load and blowout safety. GRAFILIT® SP has excellent chemical, thermal, and mechanical resistance.

GRAFILIT® SP is a gasket material used in a wide range of industries, such as gas and steam supply, chemical and petrochemical industries. Expanded natural graphite (>99% graphite purity) High resistance to media, particularly corrosive substances and chemicals. Excellent for steam applications.

GRAFILIT SF

GRAFILIT® SF is an expanded graphite-based material that has an excellent chemical and thermal resistance. Its high creep resistance and high compressibility make it suitable for highly demanding conditions in the chemical and petrochemical industries, gas supply, compressors, and pumps.

GRAFILIT IQ

This top-of-the-line graphite-based and stainless steel-reinforced composite design – allowing a uniform surface pressure distribution – combines exceptional thermomechanical properties and outstanding anti-stick performance (facilitating gasket replacement during maintenance). Its compatibility with a wide range of media, high self-oxidation resistance, and suitability for cyclic operations while being inert to flange corrosion, qualify perfectly this heavy-duty material for prolonged chemical, petrochemical, and steam applications.

For a more comprehensive range of sheet gasket materials please contact us

Please contact our sales team for further information and technical advice.

Gasket Sheet - High Temperature Continued



GRAFILIT® MultiForce

GRAFILIT® MultiForce is an expanded high-purity graphite gasket sheet with multiple stainless steel foil reinforcements, facilitating thus its handling and cutting, and allowing increased surface load. It has excellent chemical and thermal resistance, high creep resistance, and high compressibility rendering it suitable for highly demanding conditions in chemical and petrochemical installations with hot and/or corrosive media.

The combination of an oxidation inhibitor with a very low sulfur content makes this material the perfect solution for sealing applications in nuclear power plants.

MICALIT® P

MICALIT® P contains a high percentage of phlogopite mica flakes, impregnated with a silicone binder and reinforced by a tanged stainless steel insert.

It has excellent thermal, good chemical, and mechanical properties, making it suitable for high temperature and pressure applications in the automotive and steel industry for exhaust systems, gas turbines, oil and gas burners, furnaces, and ovens. It also offers good low thermal conductivity properties.

MICALIT® F

MICALIT® F contains a high percentage of phlogopite mica flakes, impregnated with a silicone binder.

It has excellent thermal and good chemical properties, making it suitable for high temperature applications in the automotive and steel industry for exhaust systems, gas turbines, oil and gas burners, furnaces, and ovens. It also offers good dielectric and low thermal conductivity properties. Is suitable for applications where temperatures of up to 1000°C can be reached.

All of Industrial Gaskets' sheeting material is available in sheet form, cut to size or to suit your design specifications

For a more comprehensive range of sheet gasket materials please contact us

Please contact our sales team for further information and technical advice.

Gasket Sheet - Modified PTFE / PTFE



Industrial Gaskets offers a wide range of PTFE sealing products that are suited for applications where chemical resistance is demanded or there are FDA or oxygen requirements. PTFE is non-conductive, making it resistant to high electric fields. PTFE, Modified PTFE and expanded PTFE are compound products which offer good mechanical, electrical and thermal properties as well as chemical resistance, a low friction coefficient and good resistance to wear.

All PTFE gaskets have excellent chemical resistance.

Modified and expanded PTFE also have improved cold flow and creep resistance.



Doniflon® 2030

DONIFLON® 2030 is a structurally enhanced PTFE gasket sheet filled with barium sulfate. It has outstanding chemical resistance to various media, same as DONIFLON® 900E; especially recommended for strong alkaline solutions under moderate temperatures and hydrofluoric acid (up to 48%). This material has enhanced creep performance compared to plain PTFE material. It is the ideal gasket material for equipment where higher bolt loads are required.

Doniflon® 2010

DONIFLON® 2010 is structurally enhanced PTFE gasket sheet filled with hollow glass microbeads. It has outstanding chemical resistance to various media, same as DONIFLON® 900E, except hydrofluoric acid. This material has enhanced creep performance compared to plain PTFE material. Its high compressibility enables very good adaptability to pressure sensitive connections of ceramic, glass, plastic-lined pipes or uneven flanges. It is recommended for pharmaceutical and food industries.



Doniflon® 2020

DONIFLON® 2020 is structurally enhanced PTFE gasket sheet filled with silica. It has outstanding chemical resistance to various media, same as DONIFLON® 900E; especially recommended for inorganic acids in all concentrations, except hydrofluoric acid.

This material has enhanced creep performance compared to plain PTFE material. It is recommended for pharmaceutical and food industries as well as LNG, Oxygen & cryogenic applications.

Please contact our sales team for further information and technical advice.

Gasket Sheet - Modified PTFE / PTFE



Doniflon® 900E

DONIFLON® 900E is an Expanded PTFE gasket sheet manufactured by hot-expansion of 100% virgin PTFE, with fibrillised isotropic structure. It has outstanding chemical resistance to various media, except molten alkali metals. Its excellent compressibility enables very good adaptability to pressure sensitive connections of ceramic, glass, plastic-lined pipes or uneven flanges. The material is very tough and can withstand high compressive loads without affecting its sealing capability. It is recommended for pharmaceutical and food industries.

Virgin PTFE

Virgin PTFE Skived Sheet is suited to more aggressive applications in the chemical or cryogenic industry or the food manufacturing where hygiene is a necessary requirement.

PTFE has the lowest coefficient of friction of all known solid materials. It also has the best electrical properties of all plastics and is virtually unaffected by weather and is chemically inert.



Expanded PTFE — Unbranded

Our unbranded Expanded PTFE sheet is made of 100% Microcellular Expanded PTFE. The special proprietary expansion process generates a highly fibrillated microstructure, making the sheet soft and pliable.

This material has excellent resistance to creep relaxation and cold flow and is exceptional in sealing damaged and uneven flanges.

Expanded PTFE is so versatile because of its capabilities to handle nearly all liquid and gases. It is incomparable in sealing fragile flanges, FRP, Plastic, Porcelain and glass lined piping or vessels due to its low compressive load to seal.

Etched PTFE

In addition to standard PTFE, we also produce specialized variants, including Etched Virgin PTFE. This modified form of PTFE undergoes specific processes to enhance its properties and expand its applicability in various industries and allows PTFE material to be adhered to a surface.

Whether you need improved adhesion capabilities or enhanced mechanical characteristics, our Etched Virgin PTFE is the product.



Please contact our sales team for further information and technical advice.

Industrial Gaskets — sales@industrialgaskets.com.au

Other Gasket Materials - Cork Sheets

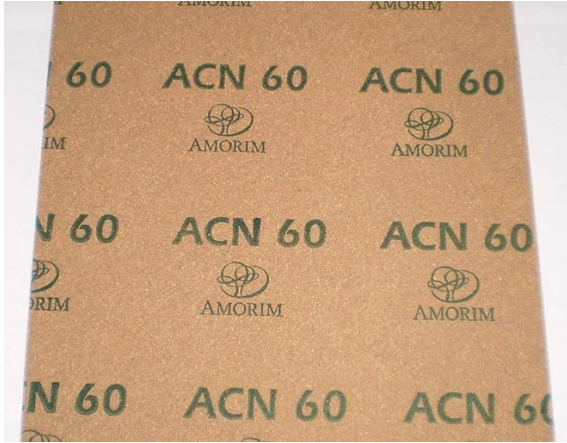

ACN60 Cork

ACN60 is a transformer grade cork manufactured with a Nitrile (NBR) Rubber binder, this high density cork is suitable for most transformer applications and compatible with the vast majority dielectric insulating oils.

It displays excellent compressive and tensile strength and typically recommended to use up to 125°C temperature and 10 bar pressure maximum.

MOW1 Cork

MOW1 Cork Sheet is made from a medium grain durable cork crumb bound together with a blended premium Nitrile rubber compound.

MOW1 Cork will display moderate resistance to oil and petroleum based products including a range of fuels, solvents and lubrication fluids.

MOW1 Cork has good physical properties including compressive strength.



ATW1 Cork - Electrical Grade

ATW1 Cork Sheet is made from a fine grain durable cork crumb bound together with a blended premium Nitrile rubber compound.

ATW1 Cork will display excellent resistance to oil and petroleum based products including a range of fuels, solvents and lubrication fluids.

It is also resistant to mineral oils.

ATW1 Cork has good physical properties including compressive strength and will display good temperature resistance.



Please contact our sales team for further information and technical advice.

Other Gasket Materials -

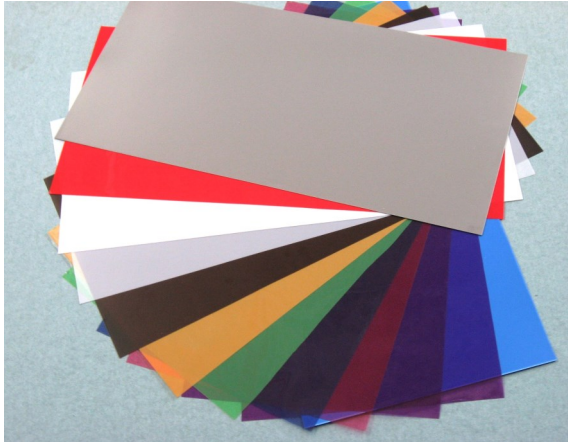

Plastic Shim

Plastic Shim is high quality with excellent wear resistance and tightly controlled thicknesses. It exhibits excellent toughness, impact strength and dielectric strength.

Our Plastic Shim is colour coded according to thickness and is widely used for spacing, mounting and gaskets. Plastic Shim sheet can be accurately cut, has good UV resistance and long term performance.

Vulcanised Red Fibre

Vulcanised Red Fibre washer is commonly used within the plumbing industry, however they have a huge range of uses within many industrial sectors.

Red Vulcanised Fibre is made from cotton pulp this makes the material swell slightly when in contact with water making it very suited for sealing of taps and other related hardware including pumping equipment.

Common Industries served : Lighting, Electrical, Motorsport, Aviation, Plumbing and Heating. Also available in black.

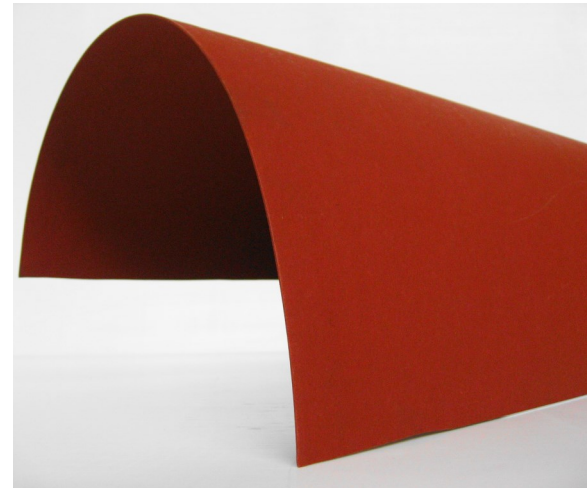

Industrial Felt

High density A Grade felt in industrial applications is used to seal in lubricants and stop contamination. Lower density firm white felt, and B Grade felt is used for lubrication, wicking, wiping and insulating.

Felt seals and gaskets are used in environments for sealing grease and oil, preventing contamination, and filtering, wicking, wiping, and insulating applications.

Available in range of thicknesses and density/grades.

Please contact our sales team for further information and technical advice.

Other Gasket Materials - Engineering & Thermal Plastics



Engineering and Thermal Plastics

Engineering plastics have gradually replaced traditional engineering materials such as metal, glass or ceramics in many applications. Besides equaling or surpassing them in strength, weight, and other properties, engineering plastics are much easier to manufacture, especially in complicated shapes .

Each engineering plastic usually has a unique combination of properties that may make it the material of choice for some applications.

Some commonly sort after plastics include Nylon, PTFE, Polyethylene, Polyurethane, Acetal, HDPE, Polypropylene, Polycarbonate and PVC.



Polypropylene

The structure of Polypropylene Sheet and Rod gives it a very high molecular mass. This makes PP Sheet and Rod highly resistant to chemicals and to aqueous solutions of salts, acids and alkalis

Polypropylene Sheet properties ensure that this material is a hard, stiff, easily workable material with excellent toughness and available in Polypropylene Sheet, Rod, Tube and Polypropylene Weld Rod.

It is an easily weldable thermoplastic which makes it ideal for tanks, fittings and vessels for the mineral processing, mining and galvanizing industries.

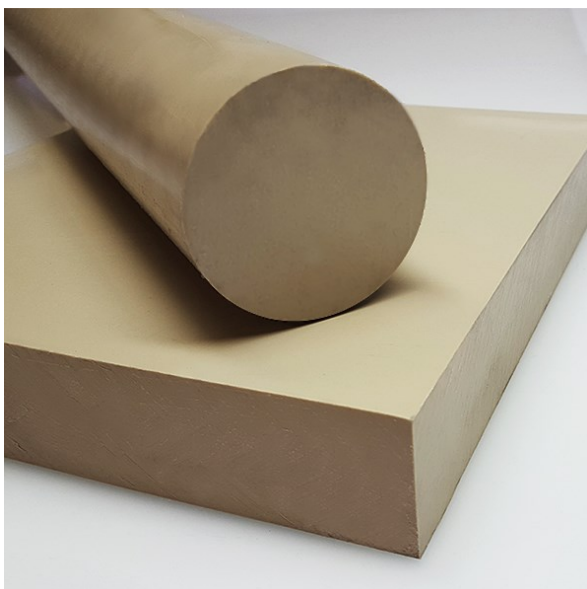

Please contact our sales team for further information and technical advice.

Other Gasket Materials - Engineering & Thermal Plastics



HMW-PE (Polyethylene)

HMW-PE is suited to engineered applications where its unique properties of excellent impact strength, wear and abrasion resistance are required. Also known as HDPE it has good sliding properties.

This material comes in various grades depending on the application and has excellent mechanical properties, supported by the rigidity and creep resistance. Available in a range of thicknesses in sheet, rod, strips, pads cut to your size requirements.

Polyurethane

Polyurethane elastomers are extremely versatile materials that can be manufactured to suit individual needs to meet a range of demanding applications. It has a high coefficient of friction; excellent grip properties and exhibits excellent compression properties and excellent tear strength with good mechanical properties.

It is extremely flexible, has good working temperature range and has good chemical resistance but is not recommended for use with strong acids and alkalis. It does however have good resistance to the effects of oxygen and ozone. Available in a range of thicknesses and colours in sheet or cut to your requirements.



Nylon

Nylon comes in many different variations and brand names, including Nylon 66 and Nylon 6. It is FDA approved in most styles and commonly used as sliding parts, bearing pads, insulation bushings, sprockets and gears. It has very good low coefficient friction and insulating properties.

Available in a range of thicknesses and colours in sheet, rod, strips, pads and washers cut to your size requirements.

Please contact our sales team for further information and technical advice.

Rubber and Elastomers



Industrial Gaskets have an extensive range of premium grade rubber sheeting and rolls.

The highly elastic properties of rubber gives our sheeting products a unique level of flexibility and compress-ability as well as excellent bearing capabilities.

Rubber material is used across a broad range of industries and are the most cost-effective materials to use where pressures are low .

It can be manufactured and supplied by the metre, in rolls or cut to specific requirements including standard gaskets, strips, washers or pads.

Cloth or Nylon inserted materials are better able to handle movement and high compression loads.

Industrial Gaskets stocks only Premium or Superior Grade rubbers so that our customers have the best product available for their application.

We are able to offer rubber products to standards including AS4020 Potable Water, WSA109, FDA and Fire Resistant.



Butyl Rubber (Isobutylene – Isoprene)

Butyl Rubber is a fully synthetic rubber made from 100% Bromo Butyl Polymer. Butyl Rubber has excellent chemical and heat resistance with low permeability to air and good weathering properties. It has however poor resistance to petroleum based fluids. It has high resistance to permeation. It has low resilience giving it excellent vibration damping and shock absorbing. properties.

Hypalon Rubber (CSM)

Hypalon is a synthetic rubber made from 100% Hypalon Polymer. It is non-ageing and has good mechanical properties. Hypalon has outstanding resistance to most chemicals, oils and heat. It has high abrasion, ozone and weather resistance. It also has excellent tensile strength and elongation.



Please contact our sales team for further information and technical advice.

Rubber and Elastomers

Silicone



Silicone Rubber

Silicone rubber displays excellent resistance to heat, weathering, ozone and a wide range of chemicals.

Silicone Rubber material does not impart taste or smell and has excellent antiaging properties. Silicone displays excellent resistance to heat, weathering, ozone and a wide range of chemicals.

It is impervious to UV light, is non toxic, chemically inert and will retain its flexibility and properties over a wide temperature range.

Silicone 60 Rubber Sheet is tested and conforms to FDA 21 CFR 177.2600 . Silicone also has low thermal and electrical conductivity and high dielectric strength. This makes it suitable for critical electrical

and electronic insulating and isolating applications.

Available in Red, Translucent, White, Blue and Black colours and a range of thicknesses.



Soft Silicone 40 Rubber

Soft Silicone 40 Rubber Sheet is made from a premium Silicone rubber compound and will display very high temperature resistance. It will maintain its flexibility and physical properties over a wide temperature range. Silicone has excellent ozone resistance and is UV stable making it weather resistant and suitable for outdoor use. Soft Silicone 40 is softer than standard Silicone and is highly flexible and compressible.

It is also conforms to FDA 21 CFR 177.2600.



Silicone Insertion Rubber

Silicone Insertion Rubber Sheet is made from a premium Silicone rubber compound and will display very high temperature resistance. It will maintain its flexibility and physical properties over a wide temperature range. Silicone Insertion rubber is reinforced with a glass fibre reinforcement which gives improved tear strength and dimensional stability.



Please contact our sales team for further information and technical advice.

Rubber and Elastomers

Viton (FKM / FPM)



Viton A Rubber

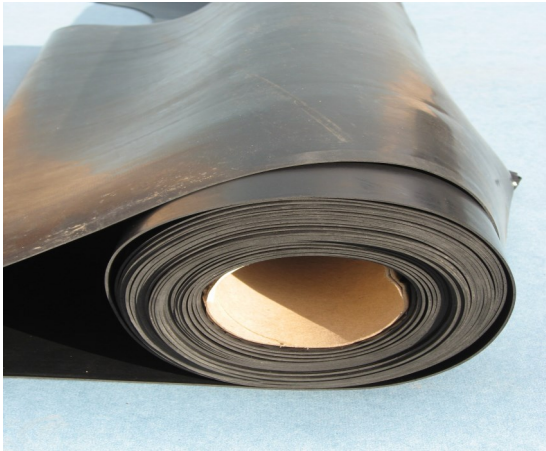

Viton is a high grade fully synthetic fluoro elastomer. Of all synthetic rubber types, Viton is the most resistant to hydrocarbons. It is non ageing and has good mechanical properties. Viton is resistant to chemicals and useful for sealing against acids and lyes of any concentration, solvents, aliphatic, aromatic hydrocarbons, Freon 12, oils and fats and gasoline. Suitable for applications with long term exposure to corrosive environments at high temperatures. It has excellent resistance to weathering and ozone. Available with Nomex reinforcement / insertion.

White (FDA) Viton Rubber



White (FDA) Viton Rubber Sheet is made from a premium fluoro elastomer compound and will display very high temperature and excellent chemical resistance to a broad range of aggressive acids. This Viton Rubber Sheet is tested and conforms to FDA 21 CFR 177.2600 "Rubber articles intended for repeated use". This makes it suitable for contact with dry, aqueous and fatty foods as defined by the FDA.



Viton B Rubber



Viton B exhibits excellent resistance to oil and petroleum-based products including a diverse range of fuels, greases, solvents and hydraulic fluids. It is also resistant to mineral acids, aliphatic and aromatic hydrocarbons. Viton B has excellent ozone/UV resistance making it weather resistant and suitable for prolonged outdoor use. It has good physical properties including mechanical strength and will maintain its fluid resistance and flexibility across a wide temperature range. It has excellent resistance to weathering and

For a more comprehensive range of rubber materials please contact us

Please contact our sales team for further information and technical advice.

Rubber and Elastomers

Neoprene - CR

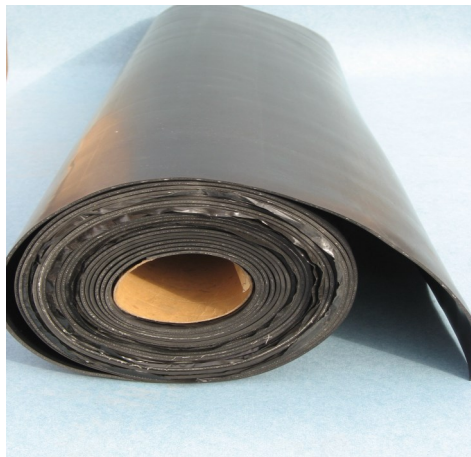

Neoprene Rubber

Neoprene 65 is a superior grade 65 Duro weather and heat resistant rubber . Neoprene is a chloroprene rubber jointing sheet, both sides smooth. It has good weathering and heat resistance and good mechanical properties. It is available with 1 ply cotton reinforcement for standard applications or a high strength nylon where extra tear resistance is required. It has excellent resistance to ageing, seawater and to all meteorological conditions. It has excellent resistance to alcohol, alkali and acid (both dilute and concentrate). Great dielectric strength for use in flange insulation.

Neoprene Nylon Insertion Rubber

Neoprene 65 Nylon Insertion sheet is made from a premium Neoprene rubber compound and will display moderate temperature and flame resistance. Neoprene Nylon Insertion is reinforced with a nylon monofilament fabric which gives improved tear strength and dimensional stability. This material has good physical properties including mechanical strength and abrasion resistance. Also available with a Cotton Insertion.



Neoprene Diaphragm Rubber

Neoprene Diaphragm is reinforced with a specifically designed nylon fabric to give a high burst strength and a good flex life. This fabric also gives improved tear strength and dimensional stability. Neoprene Diaphragm has excellent physical properties including mechanical strength and abrasion resistance. Also has excellent ozone/UV resistance.

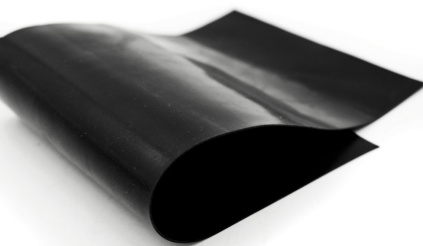

Soft 45 Neoprene Rubber

Soft Neoprene 45 Rubber Sheet is made from a premium Neoprene rubber compound and will display moderate temperature and flame resistance.

Soft Neoprene 45 is softer than standard Neoprene 65 and is highly flexible and compressible whilst still possessing all the attributes of standard Neoprene 65.



For a more comprehensive range of rubber materials please contact us

Rubber and Elastomers -

EPDM - Ethylene Propylene Diene Monomer

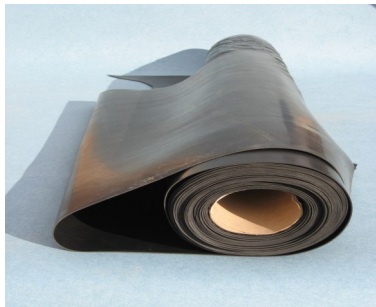

EPDM Premium Rubber

A fully synthetic rubber made from 100% EPDM Polymer. It also has basic resistance to some chemicals and acids. EPDM rubber has good ozone, weathering and temperature resistance. It is used for sealing against diluted and highly concentrated acids and lyes. Available in Potable Water Certified to AS/NZS4020 drinking water standards.

EPDM Peroxide Cured Rubber

Peroxide Cured Premium EPDM has been cured using a peroxide system making it Sulphur free and gives it superior temperature resistance and UV stability when compared to standard EPDM Premium sheet (Sulphur cured). This style of Peroxide Cured EPDM rubber has excellent ozone and weathering resistance. It is used for sealing against diluted and highly concentrated acids, alkalis and chemicals.



EPDM Premium Potable Water — AS4020:2018 Certified

Potable Water EPDM is a black premium grade Duro 70 EPDM rubber sheet, specially formulated for use in potable water applications and fully certified to AS/NZS 4020:2018. This EPDM is specifically formulated for use in applications which require contact with Potable Water and confirms to WSA-109 (2021) specifications. This material has excellent ozone/UV resistance making it weather resistant and suitable for prolonged outdoor use.



EPDM Premium Nylon Insertion

This EPDM Insertion rubber is reinforced with a nylon monofilament fabric which gives improved tear strength and dimensional stability. All other specifications remain the same as unreinforced EPDM rubber.



White FDA Superior EPDM

White (FDA) EPDM Rubber Sheet is tested and conforms to FDA 21 CFR 177.2600 " Rubber articles intended for repeated use ". This makes it suitable for contact with dry, aqueous and fatty foods as defined by the FDA. White (FDA) EPDM Rubber Sheet is made from a premium EPDM rubber compound and will display high temperature and good chemical resistance to both acids and alkalis.



For a more comprehensive range of rubber materials please contact us

Please contact our sales team for further information and technical advice.

Industrial Gaskets — sales@industrialgaskets.com.au

Rubber and Elastomers

Nitrile - Buna N / NBR



Nitrile (Buna-N) Rubber

Nitrile 65 is a fully synthetic rubber made from 100% Nitrile Rubber which has excellent resistance to petroleum based fluids and aromatics. Nitrile Rubber is suitable for sealing against oil, fuels and gas. It ages moderately well. It also has good mechanical properties, like traction, compression and impermeability to gases.

Nitrile Nylon Insertion

Nitrile 65 Insertion is made from a premium Nitrile rubber compound and will display excellent resistance to oil and petroleum-based products including a range of fuels, greases, solvents and hydraulic fluids. Nitrile 65 Insertion is reinforced with a nylon monofilament fabric which gives improved tear strength and dimensional stability.



White Nitrile (FDA) Rubber

White (FDA) Nitrile Rubber Sheet is made from a premium Nitrile rubber compound and will display excellent resistance to food based greases including a range of animal fats and plant based oils.

A high grade natural rubber with good all round properties, including resistance to abrasion. Meets with requirements of FDA Part 177, making it suitable for use in food manufacturing and handling applications.



Nitrile Diaphragm Rubber

Nitrile Diaphragm rubber is made from a premium Nitrile rubber compound and will display excellent resistance to oil and petroleum-based products including a range of fuels, greases, solvents and hydraulic fluids. Nitrile Diaphragm is reinforced with a specifically designed nylon fabric to give a high burst strength and a good flex life. This fabric also gives improved tear strength and dimensional stability.



Please contact our sales team for further information and technical advice.

Industrial Gaskets — sales@industrialgaskets.com.au

Rubber and Elastomers - Natural

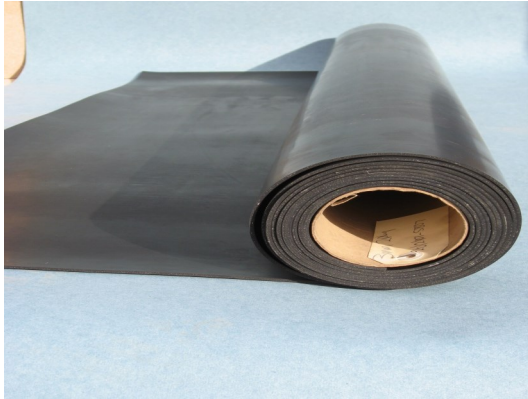

Natural 65 Premium

Natural 65 is a premium rubber that has good all round properties including resistance to abrasion. It has relatively low resistance to temperature and petroleum based fluids. It has excellent mechanical properties, good ozone, acid and alkali resistance, but not adequate for use with oils and solvents.

Natural 40 HG

Natural 40 HG is a premium grade highly flexible, compressible and resilient 40 Duro natural rubber sheet.

It is made from a highly elastic premium rubber compound and will display excellent resistance to abrasion. Natural 40 HG has excellent physical properties including mechanical strength and tear resistance. It has the capability for moderate load bearing.



SAR 60

SAR 60 Rubber Sheet is made from a highly elastic premium rubber compound and will display excellent resistance to sliding abrasion and large particle impact. SAR 60 has excellent physical properties including cut and tear resistance. It will also display resistance to some mild chemicals, including acids and alkalis used in mineral processing.



Pure Gum 35

Pure Gum 35 Rubber Sheet is made from a highly elastic premium natural rubber compound and will display excellent resistance to abrasion. It is unpigmented and is non-toxic and non-marking. Pure Gum 35 has excellent physical properties including cut and tear resistance and is extremely flexible and compressible.



For a more comprehensive range of rubber materials please contact us

Please contact our sales team for further information and technical advice.

Industrial Gaskets — sales@industrialgaskets.com.au

Rubber and Elastomers - Natural Insertion

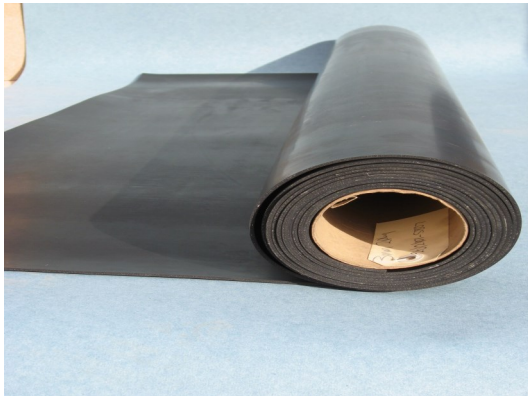

Natural 65 Premium Cotton Insertion

Natural 65 Insertion is a premium rubber that has good all round properties including resistance to abrasion. It has relatively low resistance to temperature and petroleum based fluids. It has excellent mechanical properties, good ozone, acid and alkali resistance, but not adequate for use with oils and solvents.

Natural Cotton Insertion Rubber Sheet is made from a premium rubber compound and will display moderate resistance to abrasion. Natural Cotton Insertion is reinforced with a cotton fabric which gives improved dimensional stability. Natural Insertion has good physical properties including cut and tear resistance. Available in 1Ply, 2Ply, 3 Ply and 4 Ply.

Natural 65 Premium Nylon Insertion

Natural Nylon Insertion Rubber Sheet is made from a premium rubber compound and will display moderate resistance to abrasion. Natural Nylon Insertion is reinforced with a nylon monofilament fabric which gives improved tear strength and dimensional stability. Exhibits all the properties of Natural 65 rubber. Available in a range of ply 's.



Natural Heavy Duty Nylon

Natural Heavy Duty Nylon Insertion is a premium grade 65 Duro natural rubber sheet with high strength nylon reinforcement. Made from a premium rubber compound and will display moderate resistance to abrasion and impact.

Natural Heavy Duty Nylon Insertion is reinforced with a high strength polyester nylon fabric which gives excellent cut and tear strength.

Natural Insertion has good physical properties and is extremely tough.

For a more comprehensive range of rubber materials please contact us

Please contact our sales team for further information and technical advice.

Industrial Gaskets — sales@industrialgaskets.com.au

Rubber and Elastomers - Natural Insertion



White Natural Nylon Insertion

White Natural Nylon Insertion Rubber Sheet is made from a premium rubber compound and will display moderate resistance to abrasion.

White Natural Nylon Insertion Rubber Sheet conforms to FDA 21 CFR 177.2600 . This makes it suitable for contact with dry foods, as defined by the FDA.

White Natural Nylon Insertion is reinforced with a nylon monofilament fabric which gives improved tear strength and dimensional stability.



Ventilated Natural Nylon Insertion

Ventilated Natural Nylon Insertion Rubber Sheet is made from a blended natural rubber compound. It features ventilation holes to reduce its weight and allow air flow.

Ventilated Natural Nylon Insertion is reinforced with a high strength nylon fabric which gives excellent cut and tear strength.



All rubber materials available cut to size in sheet, gasket, strip, pad or washer form.

CNC digital cutting of all materials to drawings or customers specification



For a more comprehensive range of rubber materials please contact us

Please contact our sales team for further information and technical advice.

Industrial Gaskets — sales@industrialgaskets.com.au

Rubber and Elastomer - Fire Resistant Rubber



FRAS Rubber

FRAS rubber is a premium grade 65 Duro certified Fire-resistant and Anti-static rubber sheet. It is an ideal solution for a wide range of critical sealing, insulation, isolation and protection applications. FRAS Rubber is certified Fire-Resistant and Anti-Static and is suitable for applications in underground mining and where fire potential is a high risk.

FRAS is independently tested and certified by the Mine Safety Technology Centre to meet MDG 3006 / MDG 3608 Non-metallic Materials for use in Underground Coal Mines.

FRAS has good physical properties including mechanical strength and abrasion resistance.



FRAS Insertion Rubber

FRAS Insertion Rubber Sheet is made from a premium SBR rubber compound specifically designed to be F.R.A.S. (Fire-resistant and Anti-static) rated. FRAS Insertion rubber is reinforced with a heavy PN160 fabric which gives excellent tear strength and rigidity.



Neoprene HG Rubber

Neoprene HG is a premium grade, weather, heat and flame resistant rubber sheet . Neoprene HG is F.R.A.S. (Fire-resistant and Anti-static) rated. It is independently tested and certified by the Mine Safety Technology Centre to meet MDG 3006 / MDG 3608 Non-metallic Materials for use in Underground Coal Mines.

Neoprene HG has excellent physical properties including mechanical strength and abrasion resistance and has the capability for high load bearing. It has excellent ozone/ UV resistance. Neoprene HG exhibits

good resistance to oil and petroleum based products including a range of fuels, greases, solvents and hydraulic fluids. It will also display moderate chemical resistance to acids and alkalis.

Please contact our sales team for further information and technical advice.

Rubber and Elastomers

Lining / Wear Rubbers



Linaguard (Linatrilite)® Rubber



Linatrilite® is a Nitrile (NBR) based vulcanizate reinforced with silica fillers. It is a specially blended rubber formulated specifically to give good abrasion resistance in the presence of oils and chemicals. Its features include excellent resistance to mineral/vegetable oils, greases, aliphatic hydrocarbons and other chemicals. Excellent high temperature, thermal aging and fatigue properties. Good resistance to wear with a low permeability to gases. Orange in colour for easy identification.

Chutex 40 (Pink)

Chutex 40 Skirting Rubber is made from a highly elastic premium grade natural rubber compound and will display excellent resistance to abrasion. Chutex 40 Skirting Rubber has excellent physical properties including mechanical strength and cut and tear resistance.

Commonly used for lining, wear protection, curtains and skirting applications, It will also display resistance to some mild chemicals, including acids and alkalis used in mineral processing.



R-Line NBR Lining Rubber

R-Line NBR Lining Rubber is a premium grade wear resistant Nitrile based rubber lining with a buffed back. R-Line NBR is made from a premium Nitrile rubber compound and will display excellent resistance to oil and petroleum-based products including a range of fuels, greases, solvents and hydraulic fluids. It has low gas permeability and will display good water resistance. It is also resistant to vegetable oils, mineral oils and a range of aliphatic hydrocarbons. R-Line NBR features a pre-buffed finish on one side to assist with adhesion when bonded to steel or rubber surfaces. It can be bonded using a wide range of Neoprene based rubber adhesives.

For a more comprehensive range of rubber materials please contact us

Please contact our sales team for further information and technical advice.

Rubber and Elastomers

Lining / Wear Rubbers



Regline 40 Lining Rubber

Regline 40 Lining Rubber is made from a highly elastic premium natural rubber compound and will display excellent resistance to both wet and dry fine particle sliding abrasion. It contains reinforcing fillers which gives it extra resistance to cutting and gouging by sharp particles.

It has excellent physical properties including cut and tear resistance and is very flexible. It will also display resistance to some mild chemicals, including acids and alkalis used in mineral processing.

Regline 40 features a specially formulated Neoprene based CN bonding layer to achieve ultimate adhesion when bonded to steel or rubber surfaces.

Food Grade 40 Lining Rubber

Food Grade 40 Lining Rubber is made from a highly elastic premium natural rubber compound and will display excellent resistance to abrasion. It is non-toxic and non-marking.

Food Grade 40 has excellent physical properties including cut and tear resistance and is extremely flexible. It is tested and conforms to FDA 21 CFR 177.2600 " Rubber articles intended for repeated use ". This makes it suitable for contact with dry, aqueous and fatty foods as defined by the FDA.

Food Grade 40 features a pre-buffed finish on one side to assist with adhesion when bonded to steel or rubber surfaces.



For a more comprehensive range of rubber materials please contact us

Please contact our sales team for further information and technical advice.

Rubber and Elastomer Cord & Strips



Rubber Strip

Choose your width, length and rubber or material type. All Strips available by the Meter or Roll lengths. Rubber Elastomer Strip can be supplied with adhesive backing for easy fastening to a variety of surfaces. Silicone, EPDM, Nitrile, FRAS, Viton, Neoprene, Natural, Cork, Potable Water EPDM, Skirting rubber.

Rubber Cord - Various Materials

Our extensive selection of solid rubber cords comes in diameters ranging from 1mm to 50mm. Also known as O' Ring Cord can be supplied from duro 40 through to 90. We offer a variety of polymers, including Neoprene, Nitrile, Viton®, and Silicone, to cater to your specific needs. These cords find applications in diverse sealing requirements, such as sealing outer lid gaskets for cases, automotive O-rings, sealing rubber rods in the oil industry, high-pressure gauges and meters, aeronautical, gas and petrochemical sealing applications.



EPDM Rubber Cord

EPDM solid rubber cord profiles from a high-quality EPDM compound. EPDM cords are highly popular due to their suitability for use in a wide variety of applications and working environments. This is largely due to the combination of mechanical strength and resistance the material provides. We can supply our EPDM cords in a variety of sizes from 1mm to 25mm as standard.

Pure Gum Natural Rubber Cord

Pure Gum Natural Rubber Cord is usually Tan or Black and made by using an organic material and is very resilient by not holding a shape and is self-healing.

Industrial Gaskets Natural Rubber cord is an elasticized duro 35 natural rubber designed to withstand abrasion, tear and cutting.

It is used in seals, drum pads and gaskets that require bounce and stretch capability. Sizes available are 3mm, 4mm, 5mm, 6.5mm, 8mm, 10mm, 13mm, 16mm, 19mm, 22mm, 25mm and 32mm.



For a more comprehensive range of rubber materials please contact us

Please contact our sales team for further information and technical advice.

Rubber & Elastomer - Sponge / Foam Rubber



Silicone Sponge Rubber

Silicone Sponge is made from an expanded premium Silicone compound and will display very high temperature resistance. It is closed cell foam rubber enabling it to create an easily compressible air and watertight seal.

Silicone Sponge has excellent ozone / UV resistance making it weather resistant and suitable for prolonged outdoor use. It has good physical properties and will maintain its flexibility over a wide temperature range.

Neoprene Sponge Rubber

Neoprene Sponge is an airtight and waterproof sponge which displays very good resistance to ageing, oil, alkalis, acids, solvents and a range of chemicals.

Neoprene Sponge is a good general purpose material for seals, cushions and insulation. It is a closed cell foam rubber that is UV stable.

It is an excellent gasket material where long term sealing and moderate compression recovery is required.

Available in thicknesses from 1.5mm to 40mm

Available in Sheet / Strips / Tape / Cut to specifications

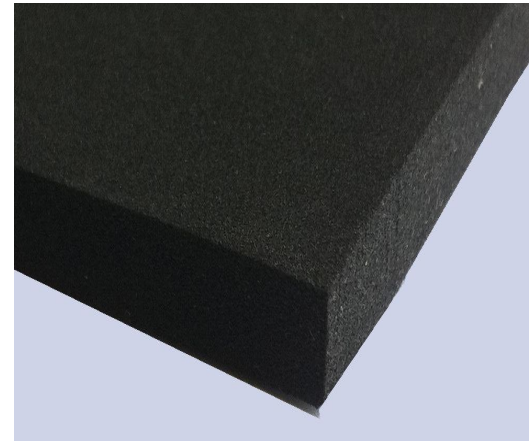

EPDM Sponge Rubber

EPDM Closed Cell Sponge has excellent weathering ability with superior resistance to UV, ozone and oxidation. It also has good resistance to oil, ageing, solvents and many other chemicals.

EPDM Sponge is a good general purpose material for seals, cushions and insulation in outdoor applications.

It is an excellent gasket material where long term sealing and moderate compression recovery is required.

Available in thicknesses from 1.5mm to 40mm

Available in Sheet / Strips / Tape / Cut to specifications



Please contact our sales team for further information and technical advice.

Steel Core Rubber Gaskets



G-ST range of Steel Core Rubber gaskets consist of a lens-shaped rubber body and an interior steel ring.

The rubber jacketing is vulcanized firmly to the steel insert which creates a sturdy compound which can withstand even high stresses. The steel insert increases the blow-out resistance and stability of the sealing system. The lens shape causes a partial increase in surface pressure. Available equipped with an O-ring as static sealing element.

Product Range



G-ST

For various applications.



G-ST/GUSS

In special dimensions.
For total covering of flange face.



G-ST-P/S

For various applications, top choice
for joints connecting non-metallic
(plastics or GRP) and steel flanges.



G-ST-P/K

To suit flange joints connecting
pairs of plastic stub ends.



G-ST-P/KN

For various applications, top choice
for partially coated flanges
and heavy duty services.



G-ST-P/HTB

For steel flange connections in
Fire Safe pipelines.



G-ST-P/OE

Flexible design gasket with
visible stainless steel insert.



G-ST-P/GR

To suit pipework with soft rubber
lining and flange faces with
soft/hard rubber coating.



Please contact our sales team for further information and technical advice.

Valve & Pump Packing



Industrial Gaskets offers an extensive range of Valve & Pump Gland Packing to suit all applications.

The most popular styles of packing are shown below.

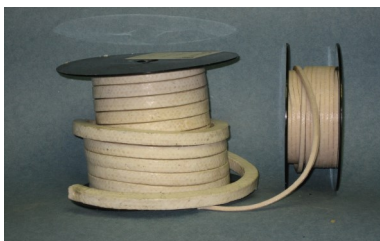

MP1890F

MP1890F is a long ramie fibre which is square and thoroughly impregnated with mineral grease and PTFE (or tallow) to make the packing pliable and resilient. A very white packing suited to use in the mid range of pH. Services-Pumps, Valves, plungers to seal hot and cold water, brine, especially suited for marine use.

Construction	Inter-braided
pH Value	5 – 9
Temperature	-50°C to 140°C
Pressure	150Psi (1050Kpa)
Speed	2000 FPM (10m/sec)



MP4130

MP4130 is a pure PTFE fibre inter-braided into a deformable square packing. A clean packing capable of handling the full pH range. It remains soft and flexible throughout service with negligible water absorption. Conforms to FDA requirements. Also available Lubricated (L) with silicon oil to enhance pump start up. Services-Pumps and Valves in strong acid & alkali services.

Construction	Inter-braided
pH Value	0 – 14
Temperature	-268°C to +260°C
Pressure	500Psi (3500Kpa)
Speed	1575 FPM (8m/sec)



MP1900

MP1900 is manufactured using synthetic fibres lattice braided for greater strength, lubricated throughout with PTFE. This packing has high strength and impact resistance. An ideal replacement for asbestos. Services-Pumps & Valves both centrifugal and reciprocating.

Construction	Polyacrylonitrile Filament Lattice braid
pH Value	2 – 12 (except strong oxidizers)
Temperature	-100°C to +250°C
Pressure	3000Psi (20684Kpa) static seal
Speed	2360 FPM (12m/sec)



MP4140

MP4140 is a virgin PTFE fibre yarn heavily impregnated with ultra pure graphite powder and lubricated with an inert lubrication. This fibre is commonly known in industry as GFO. This fibre is noted for its low coefficient of friction.

Services-Rotary & Reciprocating Pumps, Mixers, Blenders, Agitators, Valves.

Construction	Inter-braided
pH Value	0 – 14 (except strong oxidizers)
Temperature	-200°C to 280°C
Pressure	1900Psi (13,100Kpa)
Speed	2500 FPM (12.5m/sec)

Please contact our sales team for further information and technical advice.

Valve & Pump Packing

Continued

Industrial Gaskets offers an extensive range of Valve & Pump Gland Packing to suit all applications.

The most popular styles of packing are shown below.



MP4168

MP4168 is a unique packing with the strength of Kevlar® and excellent running qualities of GFO. Built to resist extrusion at elevated pressures, with minimal shaft wear, attributed to the pure Kevlar® (aramid yarn). Services-Digester pumps, chemical pumps, mixers, slurry pump, particularly suitable for pulp & paper and sugar industry.

Construction	Inter-braided
pH Value	2 – 13
Temperature	-110°C to 260°C
Pressure	300 Psi (2100 Kpa)
Speed	2250 FPM (11.25m/sec)

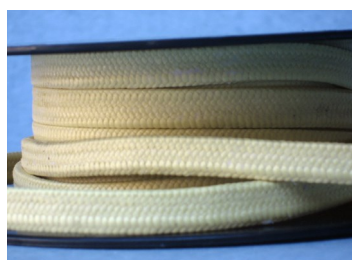

MP4188

MP4188 is an Aramid fibre (Kevlar®) impregnated with PTFE and break in lubricant. Kevlar® has a reputation of lasting under the toughest of applications. One of its features is high (excellent) abrasion resistance. Services-Extreme service in slurries, water, steam, oils, brine, many solvents, mild acids & caustics. Suited to pulp, paper & sugar industries.

Construction	Inter-braided
pH Value	3 – 11
Temperature	-268°C to +260°C
Pressure	5000Psi (3500Kpa)
Speed	2500 FPM (12m/sec)



MP1840

MP1840 is a tough low abrasion carbon fibre packing impregnated with PTFE. This packing was developed for long service against strong caustics, acids, slurries and any application where contamination is prohibited. The material has high thermal conductivity and heat dissipation. Services-Strong Acid, Alkali Hot Oil, Organic solvents, Hydrocarbon & steam, pumps & reciprocating.

Construction	Lattice Braid
pH Value	0 – 14
Temperature	-250°C to +300°C
Pressure	300Psi (2100Kpa)
Speed	4000 FPM (20m/sec)



MP8005

MP8005 is constructed from pure expanded graphite fibre yarn with corrosive inhibitors. This packing is just as capable as a valve packing in high temperatures as it is in a high speed pump. It is suited to bronze sleeves as well as stainless steel. A versatile packing developed from the old graphite tape that does away with many designer styles and makes of packing. Services-Steam Valves, boiler feed pumps, condensate pumps, chemical & petrochemical applications.

Construction	Inter- Braided
pH Value	0 – 14
Temperature	-240°C to 649°C in Steam, to 454° C in Oxidising, to 3300°C in Non-Oxidizing
Pressure	300Psi (2100Kpa)
Speed	4400 FPM (25m/sec)

Please contact our sales team for further information and technical advice.

Valve & Pump Packing

Continued

Industrial Gaskets offers an extensive range of Valve & Pump Gland Packing to suit all applications.

The most popular styles of packing are shown below.



MP8006

MP8006 is constructed from high purity graphite twisted yarn with multiple Inconel wires reinforcing each yarn. A braided core of graphite and multiple Inconel wires provide enhanced sealing & high-pressure performance. The encapsulated wire is further enhanced by applying an inhibitor & a blocking agent avoiding all contact between the reinforced inner core & the valve stem, elevating the possibility of stem scoring.

Construction	Inter-braided
pH Value	2 – 14 (except oleum, fuming nitric acid & aqua regia)
Temperature	-200°C Cryogenics +3300°C Non-oxidizing atmosphere +500°C Oxidizing atmosphere +650°C Steam
Pressure	6620 Psi (46000 Kpa)
Speed	2000 FPM (10.16m/sec)



MP200

MP200 is a lattice braid graphite fibre which can withstand elevated temperatures and aggressive chemicals. Its low coefficient of friction reduces shaft wear. It has an ideal end ring (with graph-lock* centre rings) in valve service. Services-Premium packing for steam water, petroleum, oils,

Construction	Lattice braid
pH Value	0 – 14 (except strong oxidizers)
Temperature	-200° to +455°C atmosphere to +650°C steam
Pressure	500Psi (3500Kpa) in rotary/centrifugal service
Speed	4000 FPM (20m/sec)



MP8007

MP8007 (Valv-Pac) is a corrugated or smooth formed pure graphite tape. Available with or without adhesive backing for ease of installation. Valv-Pac is able to conform to some stuffing box irregularities, It offers excellent sealing capabilities under extreme conditions for longer equipment life and less maintenance.

Purity	Lattice braid
pH Value	0 – 14 (except strong oxidizers)
Temperature	-200° to +455°C atmosphere to +650°C steam
Pressure	500Psi (3500Kpa) in rotary/centrifugal service
Speed	4000 FPM (20m/sec)



Packing Ring Set

Valve Packing Sets incorporate ultrahigh purity flexible graphite and ultrahigh purity graphite yarns to ensure low contaminant levels. High density pre-formed graphite rings form the stack with Flexible Graphite Braided top and bottom sealing rings. These rings ensure compression of the middle sealing rings and will prevent any packing extrusion. These packing sets provide maximum performance whether installed in a new valve or when repacking an installed valve.

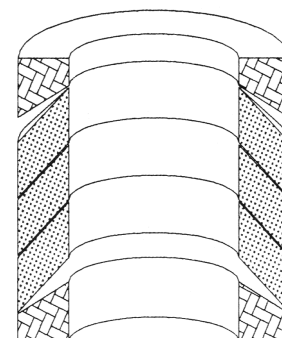

Please contact our sales team for further information and technical advice.

Valve & Pump Packing Installation Instructions

Installation Instructions for Industrial Gasket Packing

REMOVE ALL THE OLD PACKING using packing hooks, being careful not to damage the shaft/sleeve. This means all rings, even the lantern ring and the rings below the lantern. Clean the stuffing box and examine the shaft / sleeve if scored or deeply grooved, replace worn parts.

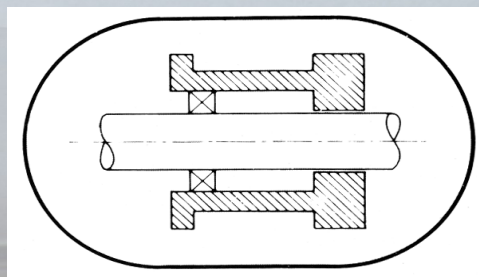

MEASURE AND RECORD SHAFT DIAMETER, STUFFING BOX BORE AND BOX DEPTH To determine the correct packing size, measure the diameter of the shaft and the stuffing box bore. Subtract the shaft diameter from the bore diameter, and divide the difference by two. This is the required cross-sectional size.

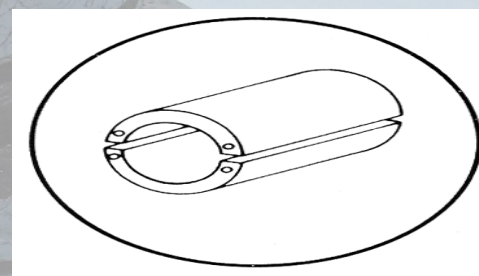

ALWAYS CUT THE PACKING INTO INDIVIDUAL RINGS Never wind the packing into a coil in the stuffing box. Rings should be cut with a butt joint. Cut rings by using a mandrel with the same diameter as the shaft in the stuffing box area. If there is no wear, rings can be cut on the shaft outside the stuffing box. Hold the packing tightly on the mandrel, but do not stretch excessively. Cut the ring and insert it into the stuffing box, making certain that it fits the packing space properly. Each additional ring can be cut in the same manner.

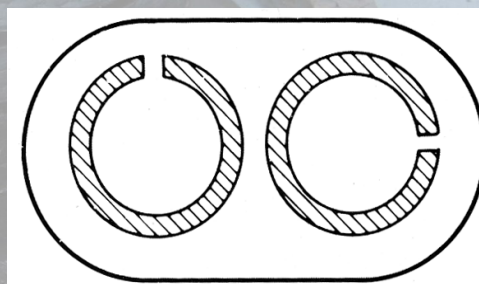

INSTALL ONE RING AT A TIME. Make sure it is clean and has not picked up any dirt in handling. Lubricate the ID of each ring lightly. Start one end and then the other, butted closely. Work around circumference from either or both directions. Joints of successive rings should be staggered and kept at least 90° apart. Each individual ring should be firmly seated with a tamping tool. When enough rings have been individually seated so that the nose of the gland will reach them, individual tamping should be supplemented by the gland.

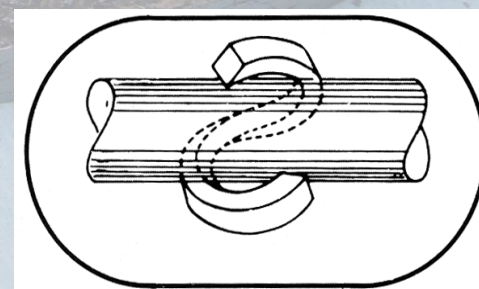

AFTER THE LAST RING IS INSTALLED Bring down the gland follower and apply 25% to 35% compression to the entire packing set. If possible, record the gland nut torque values and actuate the valve through five complete cycles (ending with the stem in the down position). Re-tighten the gland bolt nuts to the previously recorded torque value after each full actuation.

Please contact our sales team for further information and technical advice.

Valve & Pump Packing

Sundry Packings



Chevron V Packings

Vee Packings are multiple lip (chevron) packing sets designed to seal static, reciprocating and centrifugal applications. The male and female adaptors are used to complete a set of vees and to assist in sealing when compressed. Chevron Vee Packing are widely used in medium to high pressure hydraulic applications. Applications include heavy duty hydraulic pistons and rod seals. Available in wide range of materials including PTFE, Rubber and Fabric.

Packing Hook Sets

Packing Hooks extractors are the most rugged tool available for packing removal. The flexible shaft is constructed of twisted steel cable which easily conforms to close working conditions. Supplied in a set or individually.

Packing Hook Extractors are –

- Highly effective and widely used extraction tools
- Saves labour when removing packing from stuffing boxes
- Long flexible shank to gain access to glands in difficult positions
- Corkscrew tips designed to embed in all types of length for packing
- Available in a range of sizes to meet all requirements
- T-handle provides good grip for screw action and packing removal
- Size 1 – Up to 6.5mm packings
- Size 2 – 8mm to 12.7mm section packings
- Size 3 – 12.7mm and above packings
- Size 4 – 20mm packings and larger



O 'Ring & O 'Ring Kits

O 'Ring kits are available in either Imperial or Metric measurements. O-Ring kits are carried in stock in NBR 70. Also available in NBR 90 and VITON 75 materials. These kits are ideally suited for service van or field use. Each kit has around 180 pieces in standard sizes. Individual O 'Ring sizes are also available in a wide range of materials and cross sections.

Please contact our sales team for further information and technical advice.

Valve & Pump Packing

PTFE Tape & Cord



Pacseal

Pacseal is a non-toxic, non-contaminating Expanded Virgin PTFE Tape. It has a sticky back for ease of installation and removal which saves labour in cleaning and machining. It is tough but gentle making it useful in high pressure steam joints and fragile glass joints the same.

Coming in various widths, thicknesses and lengths, it is suitable in both critical and general service. The Paclon PTFE adhesive tape can be used for sealing at low bolt loads, in high temperatures.

**Standard Flanges
Flat Faced**



**Standard Flanges
Raised Faced**



Fragile Flanges



Tongue & Groove

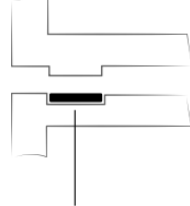

Option 1

To prevent flange rotation.



Option 2

To minimize flange rotation.

To ensure proper gasket compression, the tongue must be equal to or taller than the groove depth.



Paclon

Paclon is a non-toxic, non-contaminating expanded virgin PTFE Cord, coming in various diameters and lengths. It is easy to install and remove which saves labour in cleaning and machining.

It is tough but gentle making it useful in high pressure steam joints and fragile glass joints the same.

Typical applications include valves, flanges, ducts, tanks, evaporators, pump cases, digesters, transmission cases, compressor housings, drum lids, man ways, towers, glass joints, heat exchangers and sight glasses.

Not recommended for oxygen service.



Please contact our sales team for further information and technical advice.

Flange & Bolt Insulation

Flange Insulation Kits



FLANGE INSULATION KITS

Flange Insulation Kits are designed to combat the effects of corrosion often found in a flanged pipe system. Galvanic corrosion between dissimilar metal flanges, flange insulation associated with cathodic protection of underground piping are other examples where Flange Insulation Gasket Kits can be put to effective use.

Industrial Gaskets Flange Insulation Kits -

- Designed to minimise electro-chemical erosion
- Used to electrically isolate sections of pipework
- Comprise of materials with high dielectric strength
- Easily identified with each kit labelled with flange size & rating
- Supplied as standard with “Top Hats” or Mylar Sleeve for bolt isolation and ease of instalment, gasket and steel washers

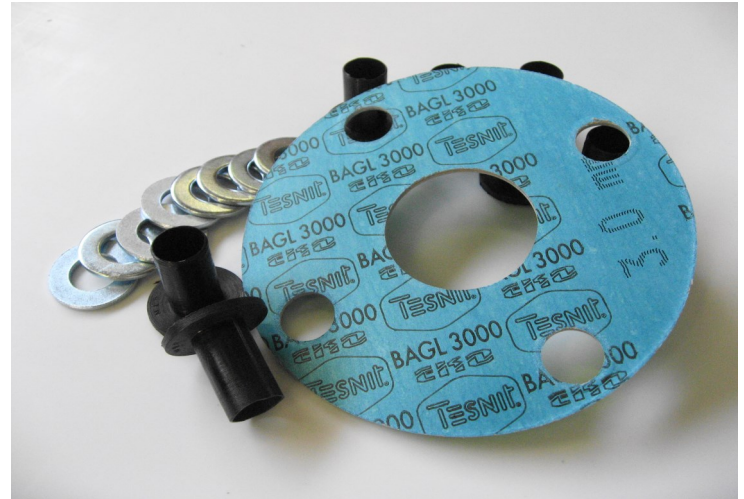

For more detailed product information please see our [Flange & Bolt Isolation Brochure](#)

Type E

Suitable for full face or raised face flanges in all Flange Standards. In this type, the gasket completely covers the flange bed to outside diameter. This design helps easy alignment of the gaskets during installation and maximum protection against foreign material “shorting out” the flange.

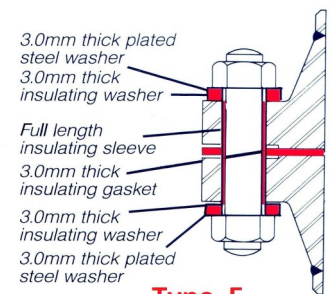

Type E

Type F

Suitable for raised face flanges only. In this type, the gasket is designed to be located inside the flange bolt circle and sits fully on the raised porting of the flange.

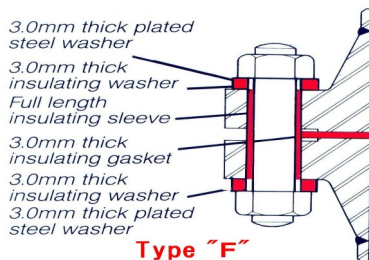

Type “F”

Type D

Specifically designed to fit the grooves of RTJ Flanges. In this type typically the gaskets are fabric reinforced Phenolic or PTFE. Available in basic oval & octagonal, RX and BX type. This type has the contact faces with oval shape. It provides a high reliability seal. These gaskets comply with ASME B – 16.20

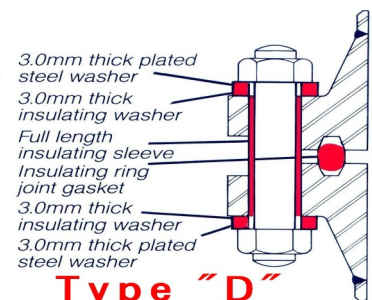

Type “D”

Please contact our sales team for further information and technical advice.

Flange & Bolt Insulation

Bolt Insulators - Sleeves



Insulating Sleeves

Industrial Gaskets offers insulating sleeves in a range of materials including Mylar, Phenolic, Epoxy and Nylon. Insulating sleeves are designed to be easily inserted in the bolt hole leaving ample room for the bolt, even when bolt holes are misaligned. Available in standard full length sizes or cut to suit your application.

Mylar Sleeve

Mylar is the most recognised and industry approved sleeve material. Industrial Gaskets recommends Mylar Sleeve as it is stronger than Phenolic and less prone to cracking during the installation process. It is available in both Metric and Imperial sizes. The standard length is 900mm or 3Ft and can be supplied in full lengths or we cut to suit your bolt length.



Nomex Sleeve

Nomex® is a material with great dielectric strength and suitable for high temperature applications up to +232°C.

Nomex® is a synthetic fiber which is flame and heat resistant.

G10 Epoxy Sleeve

G10 epoxy glass tube has extremely high mechanical strength, good dielectric loss properties, and good electric strength properties, both wet and dry. NEMA G-10 is a non-brominated, non-flame retardant grade of glass epoxy laminate.



For more detailed product information please see our [Flange & Bolt Isolation Brochure](#)

Please contact our sales team for further information and technical advice.

Flange & Bolt Insulation

Bolt Insulators - Sleeves



Phenolic Sleeve

Phenolic is suitable for general electrical applications to assist in isolating bolts from flanges when galvanic corrosion is likely to occur.

Phenolic Sleeve is also not recommended for use in alkaline environments and is unaffected by most organic solvents.

Whilst Phenolic Sleeve (and washers) have been widely used over the years it does tend to be fragile and can become brittle and crack or break if under heavy bolt torque or not handled with care. This is where Mylar Sleeve / Tube is now used in place of Phenolic Sleeve / Tube.

Top Hat Bolt Insulators

Tough, convenient-to-use, cost effective, one-piece sleeves and washers are available moulded from Mineral reinforced Nylon -Minlon®. TopHats reduce handling and make-up problems in the field.

They are moulded to specific lengths and are in many instances longer than the thickness of a single flange. Minlon® has an excellent dielectric strength and high compression strength. Industrial Gaskets Top Hats also contain a UV stabilizer.

Available for all standard bolt diameters to suit metric & imperial bolts.



For more detailed product information please see our [Flange & Bolt Isolation Brochure](#)

Please contact our sales team for further information and technical advice.

Flange & Bolt Insulation

Bolt Insulators - Washers



INSULATING WASHERS

Industrial Gaskets offers insulating washers in a range of materials that are best suited to your operating requirements. Insulating Washers are available to suit bolts in standard Metric and Imperial sizes or specialised sizes to suit your design. Insulating washers are available in a range of materials including PTFE, Compressed Fibre, Nylon, Vulcanised Fibre, Phenolic & Glass Epoxy.

Phenolic Washers

Standard insulating washers are made of high strength phenolic and provide positive insulation at temperatures to 125°C. They are made to fit over the insulating sleeves. Standard thickness is 3.2mm. Other thicknesses available on request. Phenolic washers are not recommended where high bolt torque is required as they tend to crack. Phenolic has a dielectric strength of 2.5MV/m with a water absorption rate of 1.1%.



Glass Epoxy Washers

G10 / G11 Glass Epoxy washers are tough and recommended where high bolt torque is required. Glass Epoxy maintains good dielectric and physical strength where some other materials weaken. Standard thickness is 3.2mm. Other thicknesses available on request. G11 has a dielectric strength of 60 VK, Water Absorption of 0.04% and maximum continuous operating temperature of 155°C continuous.



- ✓ Micarta
- ✓ Glass Epoxies: G3, G7, G10, G11
- ✓ Hardened-coated Steel
- ✓ Mica
- ✓ Special Orders

Other Insulating Washers

Insulating washers are also available in other materials suited for high temperature and aggressive environments. They can be supplied with Insulating Sleeve, insulating washer, an S.A.E. electroplated steel washer which is provided to protect the insulating washer from damage by the nut. Insulating gasket kits are available in single or double washer kits.

Please contact our sales team for further information and technical advice.

Flange & Bolt Insulation Specialised Flange Kits



Critical Service Flange Isolation

Integra ® Series Gaskets are exceptionally dependable for isolating and sealing purposes in severe service applications. These gaskets are applicable for :

- Isolating between flanges of dissimilar metals to prevent galvanic corrosion
- Wellhead isolation from inter-connected flow lines
- Mating mismatched dissimilar flanges
- Eliminate turbulence and flow-induced erosion between ring-joint (RTJ) flanges
- Protect against corrosion on uncoated or scarred flange faces
- Seal between flanges subjected to vibration/cavitations

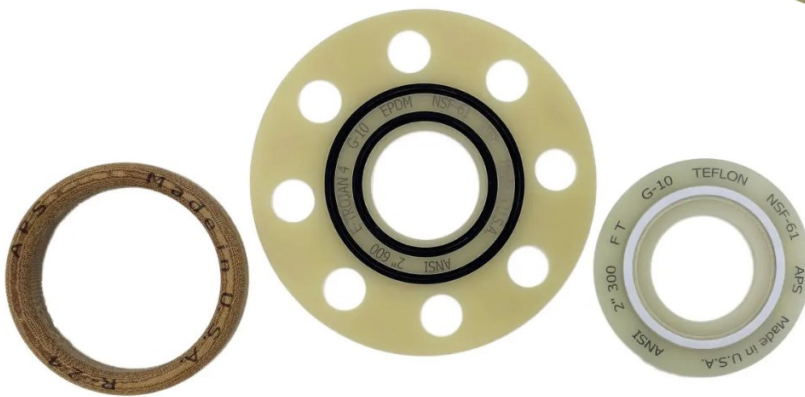

TYPE D - are specifically designed to fit into the ring groove of ring-type joint flanges.

TYPE E - is a full-faced gasket with the same outside diameter as the flange and precision cut bolt holes.

Integra II SSA® — Severe Service Gasket

The Integra II SSA® (Severe Service Application Stainless/Steel) gasket is an exceptionally dependable gasket used for both isolating and general sealing purposes in Severe Service Applications. This gasket has been developed as an inimitable and effective seal for sealing flanges in which the opportunity for leakage must be held at zero allowance. The Integra II SSA® gasket is suitable in all services up to and including ANSI 2500# and API 10,000# classes.

The Integra II SSA® gasket was exclusively designed for severe isolating service in harsh environmental applications, especially where hydrocarbons are a factor.



Please contact our sales team for further information and technical advice.

Flange & Bolt Insulation Specialised Flange Kits



Integra II SSAFS® Severe Service Fire Safe

Integra II SSAFS® isolation gasket was created to meet the demands of customers for a non metallic isolating gasket that could withstand the damaging effects of a fire. The SSAFS® ensures the most dependable sealing capability, even withstanding the severe API 6FB test. Isolation kits are available which include the fire safe gasket along with hardened steel isolation washers coated with a unique and highly durable, proprietary coating.

Refer the Integra II SSAFS® brochure for further technical specifications.

Integra II SSAXT®

Severe Service Extreme Temperature

The Integra SSAXT® flange isolation gasket kit was developed to meet the needs of our customers for a high temperature, cathodic protection gasket in severe service applications. The SSAXT® combines the reliability of a Kamm-profile retainer with the temperature capabilities of a highly dielectric mineral seal. This gasket is suitable for use in all services up to and including ANSI 2500# and API 10,000# classes. Isolation Kits are available which include high temperature washers and sleeves.

Refer the Integra II SSAXT® brochure for further technical specifications.



Integra II SSAHS®

Aggressive Chemicals Severe Service

The INTEGRA SSAHS® gasket withstands the attack of acids and other aggressive reagents, guaranteeing the sealing and tightness of the flange. Used where aggressive chemicals, including hydrogen sulfide and dry and liquid chlorine, are used. The SSAHS® combines the reliability of a stainless steel Kamm-profile ring with a non-asbestos compressed outer retainer ring and hydrogen sulfide-resistant PTFE-based seals on both sides of the gasket.



Please contact our sales team for further information and technical advice.

Flange Protection— Safety Spray Shields



Safety Spray Shields are used to prevent injury to personnel or damage to equipment in the event of a leak or spray-out of acids, caustics, chlorine, and other dangerous liquids at piping connections (such as flanges, valves, or expansion joints) found in chemical, pulp/paper, petrochemical and wastewater treatment plants. These Safety Shields are commonly referred to as flange guards, flange covers, flange diapers, or flange protectors.

Our Safety Spray Shields are constructed from PTFE, polypropylene, PVC, polyethylene, and stainless steel. They are designed to Capture Spray Outs from Faulty Flanges Carrying Dangerous Liquids.



Splash Arrestor®

Designed to Capture Spray Outs from Faulty Flanges Carrying Dangerous Liquids

Splash Arrestor® is designed from a multi-layered mesh lining made of 304 Stainless Steel that provides a controlled downward disbursement of spray outs. This metal shield is resistant up to 1093°C and pressure resistant up to 3500 PSI.

- ◆ Easy and accurate installation by one person.
- ◆ No maintenance required.
- ◆ Reusable many times over the life of the installation.
- ◆ Quick, adjustable latch can be locked with a lightweight design.
- ◆ Multi-layered wire mesh lining made of 304 stainless steel that provides a controlled downward disbursement of spray out.



Please contact our sales team for further information and technical advice.

Flange Protection— Safety Spray Shields



Cloth Options

PTFE

- ✓ PTFE coated glass cloth
- ✓ PTFE thread and drawstring
- ✓ Maximum operating temperature 232°C
- ✓ Fire and tear resistant
- ✓ Standard color is brown
- ✓ Broad spectrum of chemical resistance
- ✓ Styles available are standard, single-ply, premium, clear PTFE, and PTFE supershield

Premium



- ✓ Outlasts all other brands on market
- ✓ 3-Ply multi-layered construction
- ✓ Laboratory test proven
- ✓ High PTFE content for severe applications

PTFE Super Shield



- ✓ Solid PTFE construction (expanded PTFE cloth)
- ✓ PTFE or Nomex cord, thread, and reinforcement
- ✓ Suitable for applications where coated glass is not acceptable
- ✓ Reinforced construction through multi-layered design
- ✓ White in color

Standard



- ✓ 3-ply multilayered reinforced construction
- ✓ Laboratory test proven
- ✓ Our most popular and best selling shield

Single-Ply



- ✓ Similar in design to standard PTFE shield
- ✓ Same quality construction except single-layered for less severe applications

Clear PTFE



- ✓ Similar in design to standard PTFE shield
- ✓ 100% clear PTFE strip in center of shield allows for visual inspection
- ✓ Optional Drain Nipple

Please contact our sales team for further information and technical advice.

Flange Protection— Safety Spray Shields



Additional Cloth Options

Polypropylene



- ✓ 100% black polypropylene cloth, thread, and drawstring
- ✓ Polypropylene stiffener lines the interior for added protection.
- ✓ Maximum operating temperature 93°C

Polyvinyl Chloride (PVC)



- ✓ Manufactured from yellow, reinforced polyvinyl chloride
- ✓ Reinforced thread and drawstring
- ✓ Maximum operating temperature 170 °F

Polyethylene



- ✓ Manufactured from transparent, reinforced Polyethylene
- ✓ Reinforced thread and drawstring
- ✓ Maximum operating temperature 76°C

Pipe Vent Covers

- ✓ Designed to cover pipe vent outlets on safety relief valves and rupture discs.
- ✓ Manufactured from heavy duty polyvinyl chloride (PVC)
- ✓ Weatherproof: prevents rainwater and snow from entering pipe
- ✓ Keeps out birds and insects
- ✓ UV stabilized and chemical resistant
- ✓ Easy to install
- ✓ Contains drawstring for securing
- ✓ Contains grommet with rope attached to prevent loss
- ✓ Available for all pipe sizes
- ✓ Available in angle or straight cut



Please contact our sales team for further information and technical advice.

Industrial Gaskets — sales@industrialgaskets.com.au

Flange Protection— Safety Spray Shields



Valve Shields



- ✓ Available in same cloth and metal materials as other shields
- ✓ Manufactured to fit all types of valves:
 - Butterfly
 - Globe
 - Check
 - Diaphragm
 - Gate
 - Ball
 - Plug

Expansion Joint Shields

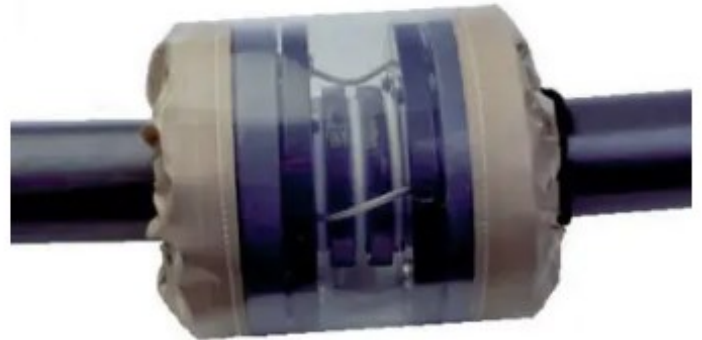

- ✓ Manufactured from single, clear, and standard PTFE only
- ✓ Same quality design as other cloth shields
- ✓ pH indicating patch to signal leaks
- ✓ Weep holes behind patch allow indicator to change color
- ✓ Attached by Velcro fasteners and drawstrings
- ✓ Allows for movement of the expansion joint without any change in effectiveness
- ✓ Available for all brands and styles of expansion joints

Please contact our sales team for further information and technical advice.

Flange Protection - Kleerband®



Kleerband® Flange Protectors

Kleerband® Flange Band Protectors eliminate the possibility of foreign matter lodging or corrosion building up between flange faces.

They are designed to protect studs and gaskets on raised face and ring type joint flanges from atmospheric corrosion encountered in chemical plants, refineries, gas plants, offshore platforms, onshore oil fields, ships, paper mills and underground pipelines.

Kleerband® Flange Protectors are manufactured of 100% virgin vinyl compound, which allows visual inspection of the flange surface without removing the flange protector. This system totally eliminates any possibility of foreign matter lodging between the faces of your flange or corrosion bridging across and creating a short.

Stainless Steel Flange Protectors

For High Temperature Applications — Stainless Steel Flange Band Protectors are manufactured of 304 or 316 stainless steel 22 gauge band, stainless steel worm-gear strap, and grease fitting.

An exclusive positive loading relief vent and plug assures the complete loading of flange cavities and allows you to visually inspect the flange without removal of the protector, which is standard. The gasket is made of 3/16" closed cell neoprene for a positive seal. This system totally eliminates any possibility of foreign matter lodging between the faces of your flange or corrosion bridging across and creating a short.



For more detailed product information please see our [Flange & Bolt Isolation Brochure](#)

Please contact our sales team for further information and technical advice.

Flange Protection - Radolid® Protection Caps



Radolid® Protection Caps

Radolid® Protection Caps are used to eliminate corrosion of nuts and bolts and allow quick removal when necessary. These caps are easily installed by pressing the cap onto the bolted joint by hand. Radolid® Caps barbed edges snap in place, preventing the caps from accidentally being removed.

Standard Radolid® Caps are manufactured with low density black UV-resistant polyethylene that withstands temperatures of -84 °F to +210 °F. They are reusable and can be reapplied 2-3 times.

They are also resistant to water, brine, hydraulic fluid, diesel, greases, gasoline, hydrochloric acid concentrate, sulfuric acid to 40%, nitric acid to 40%, ammonia, and acetum.

Standard Radolid® Protective Caps are black, but they are also available in clear, white, red, grey, silver and other colors on request.



Radolid® for Wind Turbines

Radolid® Nut & Bolt Protection caps for Wind Turbines. These Radolid® 's are manufactured with low density, UV-resistant polyethylene. Radolid® is easy to install, reusable, and will protect your nuts and bolts from corrosion.

- ◆ Operating Temperatures – 64°C to 98°C
- ◆ Self cutting threads for a firm and secure hold
- ◆ Various heights for different excess bolt lengths
- ◆ Suitable for Wind Turbines and anchor bolts



For more detailed product information please see our [Flange & Bolt Isolation Brochure](#)

Please contact our sales team for further information and technical advice.



Woven Plain Fibreglass Tape

Style FGT is fibreglass fibres woven into tape form. It is user friendly in so much as particle emission is minimized due to process, therefore reducing the chance of irritability when being applied in the workplace. It does not shrink with atmospheric changes. The tape will not support combustion or burn. It is unaffected by most dilute alkalis and acids. Usual applications include welding blankets, lagging on pipe work, insulation and expansion joints.

Woven Fibreglass Ladder Tape

Style FGTL is fibreglass fibres woven ladder tape. It is user friendly in so much as particle emission is minimized due to process, therefore reducing the chance of irritability when being applied in the workplace. It does not shrink with atmospheric changes. The tape will not support combustion or burn. It is unaffected by most dilute alkalis and acids. Applications include wrapping steam tracer lines, hose, piping, tadpole tapes, gasketing, boiler close up and duct flanges.



Fibreglass Tadpole Tape

Tadpole Tape has a high temperature, heat & flame resistance. The thermal insulating fibreglass tadpole tapes are fabricated with high quality type E fibreglass that will not burn and will withstand continuous exposure to temperatures up to 520°C. Commonly used as a gasket or seal for access doors and gate valves and other applications. The core portion in the bulb is a twisted fibreglass rope. A side profile of the tape represents the shape of a Tadpole, hence the name. This material resists most acids and alkalis and is unaffected by most bleaches and solvents.

Fibreglass Woven Cloth

Style FGC is fibreglass fibres woven into cloth form. It is user friendly in so much as particle emission is minimized due to process, therefore reducing the chance of irritability when being applied in the workplace. It does not shrink with atmospheric changes. Usual applications include welding blankets, lagging on pipe work, insulation and expansion joints.



Fibreglass Bulk Rope & Sleeving

Fibreglass Rope comprises of fibres twisted into yarn/rope and braided into either round or square form. Smaller sizes are fully braided as the larger sizes can, if required, be braided over a core to make manufacturing more economical. Density of the core is either soft or hard. Fibreglass Tube Sleeving is designed for fitting over cable or cords to protect from damage. Available coated in silicone.

Please contact our sales team for further information and technical advice.

Ceramic fibre ropes, tapes and textiles are produced by processing refractory ceramic fibre yarn.

Industrial Gaskets ceramic fibre textiles are woven or braided from yarn consisting of refractory ceramic fibre. Insert materials are incorporated into the yarn to increase fabric tensile strength. Alloy wire inserts are available for obtaining maximum strength at elevated temperatures. Glass filament inserts are used in applications where electrical resistance is required.

Industrial Gaskets ceramic fibre textiles be used up to 1000°C+, however, when tensile strength is important the temperature limits of the insert materials should be considered. Products available include Blanket, Tape, Sleeve, Yarn, Twisted Rope, Braided Rope and Cloth.



Ceramic Fibre Blanket

The Ceramic Fibre Blanket has excellent thermal stability and thermal shock resistance. This material has low thermal conductivity, low heat and storage. Temperature rated to 1260°C. Applications including furnace lining of every type, industrial furnace and heating equipment, metallurgy, machine construction and materials, petrol and chemical engineering.

Ceramic Fibre Tape & Ceramic Fibre Ladder Tape

Ceramic Fibre Tape is manufactured from ceramic fibre yarn which is reinforced with either glass or Inconel wire. It is suited for high temperature, low pressure applications where poor flanges or low bolt loadings are present. Typical applications are for ductwork flange gasket, furnace / boiler door seals and cable and pipe protection. Ceramic Tape is rated to 1000°C.



Twisted Ceramic Fibre Rope

Twisted rope consists of a multiple of ceramic yarn strands which can be either fibreglass or stainless steel reinforced with a single filament glass fibre or alloy wire depending upon use temperature. These products are especially recommended for heavy duty applications. Ceramic Twisted Rope is rated to 1000°C. Ceramic Fibre is non combustible.

Ceramic Woven Cloth

Ceramic Fibre Cloth is a high temp fabric made from ceramic yarn, available in a number of different thickness and construction to provide a comprehensive high temperature range. Optionally reinforced with either filament, 316SS or Inconel wire.



Please contact our sales team for further information and technical advice.

Expansion Joints - Metallic & Non Metallic



Expansion Joints are used in piping systems to absorb thermal expansion or terminal movement where the use of expansion loops is undesirable or impracticable or there is vibration or noise reduction required. Pipe Expansion Joints are available in all standard pipe sizes and a range of materials depending on the application. A bellow is made up of a series of one or more convolutions, with the shape of the convolution designed to withstand the internal pressures of the pipe, but flexible enough to accept the axial, lateral and /or angular deflections. The most common styles are detailed below.

Pipe Expansion Joints are also known as “compensators” as they compensate for the thermal movement.

Single Sphere Expansion Joint

Rubber Expansion joints provide superior movement capability in axial compression, axial extension and lateral deflection, as well as in the angular and torsional direction. This performance cannot be obtained with metallic joints or grooved couplings. They contain floating flanges (non fixed) to allow for easy alignment in a range of materials including 316 Stainless Steel, Mild Steel and Galv Coated. Also available with Control / Tie Rods to enhance its pressure capability in unanchored systems, and to control the movement of the joint.



Twin Sphere Expansion Joint

Twin Sphere Rubber Expansion joints are ideal for applications requiring large axial, lateral and angular movements. They contain floating flanges (non fixed) to allow for easy alignment in a range of materials including 316 Stainless Steel, Mild Steel and Galv Coated.



PTFE Expansion Joints

PTFE Expansion Joints are flexible connectors and tremor barriers designed to compensate for misalignments absorb expansion and contraction, and isolate vibration and shock in process piping, tanks and pumps. PTFE expansion joints have a proven record worldwide handling the chemical process industry's most corrosive pipe stress problems. They are formed from isostatically moulded, FDA approved, virgin PTFE resin. PTFE Expansion Joints have almost universal chemical inertness, high and low temperature resistance, invulnerability to ozone and sunlight, outstanding flex life.

Metal Expansion Joints

Metal Expansion joints or Exhaust Bellows are the most important part of an exhaust system as they act as a shock absorber isolating engine vibration from exhaust systems to avoid metal fatigue and ultimate failure. The bellow is made up of a series of convolutions which assist in the axial and lateral movements.



Please contact our sales team for further information and technical advice.

Chemtools®

Chemtools® is a leading Australian manufacturer of Adhesives & Sealants, as well as bulk and aerosol Lubricants & Greases, Cleaners & Degreasers, and a wide range of industrial maintenance products used in the Building & Construction, Automotive, Welding, Plumbing, Electronics, and Electrical industries.

Industrial Gaskets is proud to be a Distributor of the Chemtools® range of Industrial products.

The comprehensive product range includes Anaerobic Adhesives (Thread locker, Thread sealant, Gasket compounds) , Structural Adhesives, Anti-Corrosion and Anti-Seize compounds, Greases and Lubricants just to name a few.



CHEMTOOLS 8406 RAPIDSTICK INSTANT ADHESIVE WICKING GRADE RUBBER & METAL BONDING

Rapidstick 8406 Cyanoacrylate Adhesive is ideal for a wide variety of manufacturing and repair applications requiring a reliable, high strength, industrial bond. Available in a range of sizes.

- High Strength / Fast Curing / 24 Hour Full Cure Time

CHEMTOOLS 8609- RAPIDSTICK FAST CURE RETAINING COMPOUND

Rapidstick 8609 Retaining Compound is a fast curing, low viscosity, medium strength compound with high temperature resistance.

- Medium Strength / Fast Curing / 10 Minutes Handling Cure Time



CHEMTOOLS R42 MOLYTACK GREASE

DEOX R42 Molytack Grease is a premium, lithium complex thickened grease formulated for a wide variety of applications.

- Long lasting corrosion protection / High drop point / Contains rust inhibitor

Please contact our sales team for further information and technical advice.

Couplings - Straub®



Straub ® Couplings

The Straub pipe coupling concept is backed by over 40 years of experience and continuous development, guaranteeing Swiss quality and value.



Straub® Couplings are the easiest way to join pipes of all materials. They require no special tools or pipe-end preparation. Flexible, lightweight, 316SS construction; Straub® Couplings handle pipe misalignment, vibration, and are used in ship building, wastewater treatment, general industry, and construction.

They will replace welded, flanged, threaded, or grooved type pipe joints. Straub® Hi-Performance Pipe Couplings, are the 21st Century way to join pipes.

Available in diameters from 1" to 120 " .

Straub® Couplings come fully assembled and ready to install. A torque wrench is the only tool required to do the job. Light weight and with a low profile, Straub® Couplings are easy to handle and can be installed in the tightest of spaces. The unique lip seal design seals on even rough pipe surfaces.

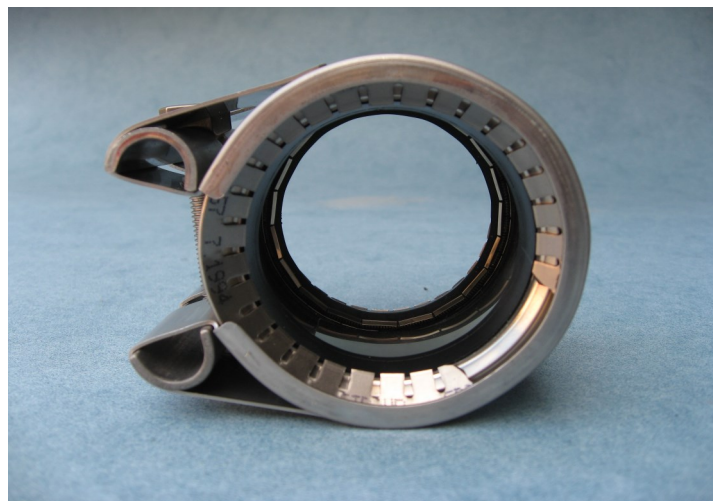

STRAUB® Couplings are used to join virtually any plain end pipe or tube including steel, stainless steel, ductile iron, FRP, PVC, CPVC, C900, concrete pipe, copper and CuNi piping.

Straub® Pipe Repair Clamps

Also available is a range of Pipe Repair Clamps. The Straub Clamp® repair clamps are designed to safely and reliably seal damaged pipes made from a range of materials (steel, cast iron, ductile cast iron, fibre cement, PVC etc).

Straub Clamp® repair clamps are available in sizes from OD 44mm to OD 440mm.

Please contact our sales team for further information and technical advice.

Couplings - UNI-Coupling ®



UNI-Coupling ®



A quality European coupling made in Denmark.

High flexibility and safety determine the basis for the UNI-Coupling. With a unique patented sealing solution and anchoring effect, you can rely on our pipe couplings. The UNI-Coupling applies this solution to two basic types, making it possible to mount it on any type of pipe.

Pipe couplings can be used almost anywhere where there is a pipe or pipes to connect. They can be used to connect metal to metal pipes, metal to plastic, and plastic to plastic. They can be used on PE, PVC and GRP, or concrete and even rubber-lined pipes.

- Speed of Installation and Ease of Use
- Light weight (less manpower required to get them into place)
- Compensate for: axial shifts / pipe length changes / angular deflection
- manufacturing and fitting tolerances (real world ready)
- Removable and reusable (unless damaged, of course)
- Very short construction and down times thanks to simple, fast installation and removal (productivity benefits)
- Easy repair, modification and refurbishment of existing plant (freedom of design, and future-proofing)



Minimal space required to store spare pipe couplings for emergencies or future projects

Grip-type couplings provide axial restraint, and compensate misalignment and angular deflection

Flex-type are *not* axial restraint, but otherwise can do all this and more and, in addition, cope with vibrations such as from a pump, or the expansion and contraction caused by temperature changes.



Please contact our sales team for further information and technical advice.

Torque Saver Gasket



Torque Saver Gasket (Tombo ®)

Superior low-torque gaskets for metallic or non-metallic flanges

Torque Saver Gaskets offer the same sealing performance with 1/3 bolt tightening torque compared with flat envelope style gaskets. Suited to Chemical, Petrochemical, Food, Medicine and other industries where corrosive medium or high cleanliness is required for pipe flange sealing.

- Raised molded-in sealing rings seal with 75 % less surface area for excellent performance in non metallic flanges (e.g HDPE, FRP, CPVC, Polypropylene & PVDP)
- Reinforced bolt holes
- Limited Creep and Cold Flow
- Locating tab on gasket for ease of installation
- Long service life
- Recommended and manufactured to suit #150 flat face flanges



Torque Saver Gasket - Style SR (Solid Rubber)

Features: EPDM Rubber molded gaskets have a cross section shape. Reliable sealing performance is obtained even at lower seating stress than that of a traditional rubber gasket. Recommended for locations where service conditions are not critical and chemical resistances is not particularly required.

Service Temperature : -40°C to + 150°C

Maximum Service Pressure: 2.0MPa

Torque Saver Gasket - Style PJ (PTFE Jacketed)

Features: EPDM rubber molded gasket having the same cross sectional shape as Style SR, but the sealing surface is jacketed with PTFE film. This gasket has the elasticity of rubber and the corrosion resistance of PTFE. It simultaneously gives good sealing performance. Ideal for applications such as PVC and glass lining piping where only low seating stress is attainable.

Service Temperature : -30°C to + 150°C

Maximum Service Pressure: 2.0MPa



Please contact our sales team for further information and technical advice.



TECHNICAL INFORMATION



Technical Rubber Compound Guide



PHYSICAL PROPERTIES OF RUBBER

PRODUCT	ASTM	Gauge Range (mm)	Hardness Shore A	Max Temp °C	Tensile Strength (MPa)	Elongation %	Abrasion Resistance	Ozone/UV Resistance	Oil Resistance	Acid Resistance	Main Application
Butyl Rubber / Isobutylene-Isoprene	IIR	1.5 - 6.0	65±5	110	7	300	Fair	Excellent	Poor	Excellent	Heat/Chemical
Chute Rubber	NR	1.5 - 25.0	40±5	70	18	550	Excellent	Good	Poor	Fair	Lining
Ethylene - Insertion	EPDM	1.5 - 6.0	65±5	120	10	350	Fair	Excellent	Poor	Good	Heat/Ozone
Ethylene - Propylene	EPDM	1.0 - 25.0	65±5	120	10	350	Fair	Excellent	Poor	Good	Heat/Ozone
Ethylene - Propylene (Peroxide Cured)	EPDM	3.0 - 6.0	65±5	140	8	300	Fair	Excellent	Poor	Good	Heat/Ozone
Ethylene - Propylene Potable	EPDM	1.5 - 6.0	65±5	120	11	350	Fair	Excellent	Poor	Good	Potable Water
Hypalon Rubber	CSM	1.5 - 6.0	65±5	120	9	300	Good	Excellent	Good	Excellent	Heat/Acid/Chemical
Natural	NR	0.8 - 12	65±5	70	7	350	Good	Fair	Poor	Fair	General Purpose
Natural Insertion	NR	1.5 - 9.0	65±5	70	7	350	Good	Fair	Poor	Fair	General Purpose
Neoprene / Chloroprene Insertion	CR	1.5-6.0	65±5	80	7	300	Fair	Excellent	Good	Fair	Heat/Oil/Ozone
Neoprene / Chloroprene	CR	0.8-25.0	65±5	80	7	300	Fair	Excellent	Good	Fair	Heat/Oil/Ozone
Nitrile / Buna N	NBR	0.8 - 25	65±5	90	15	400	Good	Fair	Excellent	Good	Petrol and Oil
Nitrile / Buna N Insertion	NBR	1.5 - 6.0	65±5	90	15	400	Good	Fair	Excellent	Good	Petrol and Oil
Pure Gum	NR	0.8-6.0	35±5	70	20	700	Excellent	Poor	Poor	Fair	Soft, High Flexibility
Silicone Rubber - Red	VQM	0.3 - 12.0	60±5	200	7	250	Fair	Excellent	Good	Excellent	Heat/Ozone/Chemical
Silicone Rubber - Translucent	VQM	0.5 - 10.0	60±5	200	7	250	Fair	Excellent	Good	Excellent	Heat/Ozone/Chemical
Silicone Rubber - White	VQM	1.0 - 10.0	60±5	200	7	250	Fair	Excellent	Good	Excellent	Heat/Ozone/Chemical
Viton A Rubber	FKM	0.5 - 10.0	70±5	200	7	200	Fair	Excellent	Excellent	Excellent	Solvent/Heat/Chemical
Viton A Rubber - Nomex Insertion	FKM	1.5 - 3.0	75±5	230	7	175	Fair	Excellent	Excellent	Excellent	Solvent/Heat/Chemical
Viton B Rubber	FKM	3.0	75±5	220	8.5	175	Fair	Excellent	Excellent	Excellent	Solvent/Heat/Chemical
Linatrilite	NR	3.0-6.0	38	70	44	830	Fair	Fair	Poor	Fair	General Purpose
White Hygienic (Natural Rubber)	WHR	3.0 - 6.0	40±5	70	19	650	Good	Fair	Fair	Fair	Food Grade
White Nitrile	WHR	0.8 - 12.0	55±5	90	6	350	Good	Fair	Excellent	Good	Food Grade

Please contact our sales team for further information and technical advice.

TROUBLE SHOOTING LEAKING JOINTS

One of the best available tools to aid in determining the cause of leakage is a careful examination of the gasket in use when leakage occurred

Observation	Possible Remedies
Gasket badly corroded	Select replacement material with improved corrosion resistance
Gasket extruded excessively	Select replacement material with better cold flow properties, select replacement material with better bearing capability – i.e. more dense
Gasket grossly crushed	Select replacement material with better load bearing capability, provide means to prevent crushing the gasket by use of a stop ring or re-design of flanges
Gasket mechanically damaged due to overhang of raised face or flange bore	Review gasket dimensions to ensure gaskets are proper size. Make certain gaskets are properly centered in joint
No apparent gasket compression achieved	Select softer gasket material. Select thicker gasket material. Reduce gasket area to allow higher unit seating load
Gasket substantially thinner on OD than ID	Indicative of excessive “flange rotation” or bending. Alter gasket dimensions to move gasket reaction closer to bolts to minimize bending movement. Provide stiffness to flange by means of back-up rings. Select softer gasket material to lower required seating stresses. Reduce gasket area to lower seating stresses
Gasket unevenly compressed around circumference	Improper bolting up procedures followed. Make certain proper sequential bolt up procedures are followed
Gasket thickness varies periodically around circumference	Indicative of “flange bridging” between bolts or warped flanges. Provide reinforcing rings for flanges to better distribute bolt load. Select gasket material with lower seating stress. Provide additional bolts if possible to obtain better load distribution. If flanges are warped, re-machine or use softer gasket material

Please contact our sales team for further information and technical advice.



HOW TO INSTALL AND USE GASKETS IN THE FIELD?

Successful sealing of a flanged connection depends upon many elements of a well-designed flanged system working well together. Here is a summary, which should serve as a guideline for maintenance operators, engineers, and fitters in order to ensure successful gasket installation and assembly of bolted flange connections.

TOOLS REQUIRED

Special tools are required for cleaning and tensioning the fasteners. In addition, always use standard safety equipment and follow good safety practice. Prepare the following equipment prior to installation:

- calibrated torque wrench, hydraulic or other tensioner,
- wire brush,
- lubricant,
- helmet and safety goggles,
- other plant-specified equipment.

1. Clean and examine

Remove all particles and debris from seating surfaces, fasteners (bolts or studs), nuts, and washers. Use plant-specified dust control procedures. Examine fasteners (bolts or studs), nuts, and washers for defects such as burrs or cracks. Examine flange surfaces for warping, radial scores, heavy tool marks, or anything prohibiting proper gasket seating. Replace components if found to be defective.

2. Align flanges

Align flange faces and bolt holes without using excessive force. Report any misalignment.

3. Install gasket

Verify if the gasket is of the specified size and material. Carefully insert gaskets between the flanges. Make sure the gasket is centred between the flanges. Do not use "jointing compounds", graphite, grease or release agents on the gasket or seating surfaces. Bring flanges together, ensuring the gasket isn't pinched or damaged.

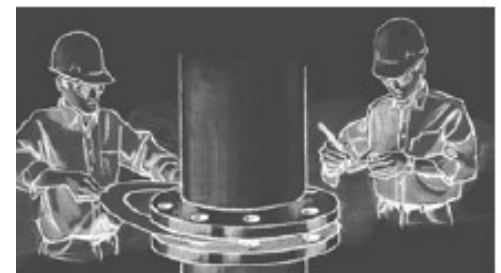
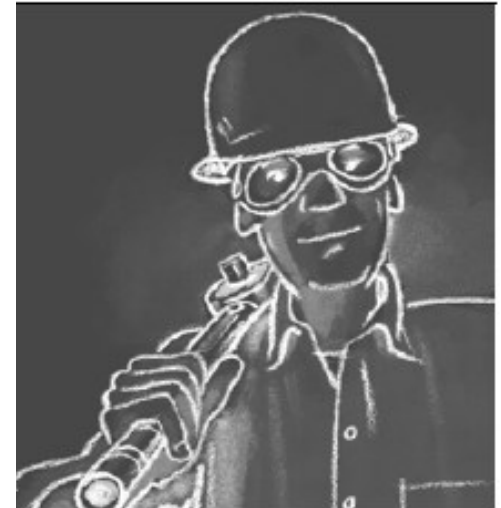

4. Lubricate load-bearing surfaces

Use only specified or approved lubricants. Liberally apply lubricant uniformly to all thread, nut, and washer load-bearing surfaces. Ensure lubricant doesn't contaminate either flange or gasket face.

5. Install and tighten bolts

Always use proper tools: calibrated torque wrench or other controlled-tensioning device. Consult our Technical expert or use the Gasket calculation software DON for guidance on torque specification.

Always torque nuts in a cross bolt-tightening pattern. Tighten the nuts in multiple steps:

- step-1 Tighten all nuts initially by hand. (Larger bolts may require a small hand wrench.)
- step-2 Torque each nut to approximately 40% of full torque.
- step-3 Torque the nuts to approximately 70% of full torque.
- step-4 Torque each nut to full torque, again using the cross bolt-tightening pattern. (Large-diameter flanges may require additional tightening passes.)
- step-5 Apply at least one final full torque to all nuts in a clock-wise direction until all torque is uniform. (Large-diameter flanges may require additional tightening passes.)

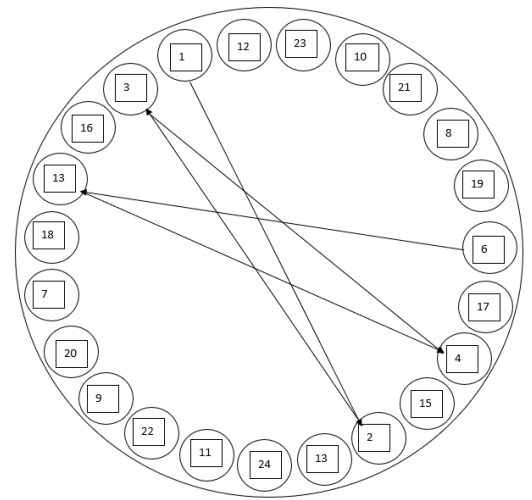

6. Retightening

Do not retorque elastomer-based, asbestos free gaskets after they have been exposed to elevated temperatures unless otherwise specified. Retorque fasteners exposed to aggressive thermal cycling. All retorquing should be performed at ambient temperature and atmospheric pressure.



WHAT IS A SEGMENTED GASKET AND WHEN YOU SHOULD USE ONE

Segmented gaskets are manufactured by joining together multiple sections of material. Joining techniques employed include dovetailing, scarf cut and butt-joining.

Segmented gaskets are often necessary due to either the limited manufactured size of the sheet or to minimize waste generated with large centres.

There are a number of situations where your product or process may require segmented gaskets. Because of how sheets of gasket material are manufactured, some pieces of machinery are too big to utilize a single-piece gasket.

You can also use segmented gaskets to get better yield from a sheet of gasket material minimizing the waste generated with centres.

The best solution is to cut the joint using a dovetail or puzzle pattern. The material will flow tighter under compression, creating a tighter and longer-lasting seal. When done properly, this method should not require additional sealant, which can have a negative impact on the gasketing material.

With dove-tail jointing, the gasket is put together from individual segments. This can optionally be done at site, which is easier from a packaging and logistics point of view especially in case of very large gaskets



The question of whether a gasket material can make and maintain a seal depends not only on the material's quality, but the medium being sealed, the design of the flange, the amount of pressure applied to the gasket by the bolts and the way the gasket is assembled into the flanges and tightened.

GENERAL RECOMMENDATION ON GASKET USE

The following information is for general guidance only. Please contact one of our sales team for further clarification.

Yes	No
Use gasket material and bolt grades that suit the tensile loading requirements of the flange	NEVER reuse an old gasket
Check that the gasket is compatible with the media at required operating temperature and pressure ranges	Do not use low quality gaskets or jointing. Any initial cost savings will soon be lost in downtime caused by joint failures
Non-metallic gaskets should be stored flat, at a moderate temperature (ie +15°C to + 20°C), in dry conditions, away from direct sunlight and heat and remote from any electrical equipment that may produce ozone	Never use sealing compounds or grease on joints. They reduce the friction between the gasket and its flanges which can allow a gasket to stress-relax and creep, leading to premature failure
Ensure flanges are clean, undamaged, free from grease and oil and has correct surface finish	Avoid using impact adhesives or pressure sensitive tapes at temperatures exceeding 40°C. Above this temperature the tackifying resins may melt and act as a lubricant
Specify the thinnest gasket that will suit the flange finish and parallelism	Do not mate flange faces that have different surface finishes
Lightly lubricate the flange bolts and check that the nut can run freely down the threads before use	Do not retighten bolts after use at elevated temperatures on flanges sealed with gaskets of compressed fibre
Tighten down the gasket evenly in several stages using an approved bolting sequence. This avoids flange distortion and gives an even stress distribution within the gasket	
Ensure the gasket is the correct size for the flange	

Please contact our sales team for further information and technical advice.



Australian Owned & Operated Manufacturer and Supplier of Quality Gaskets for Over 35 Years



Industrial Gaskets

Unit 2 /4 Iris Street

Melrose Park South Australia 5039

Email: sales@industrialgaskets.com.au

Phone: +61 (08) 8276 4140



All information and recommendations contained in this publication are to the best of our knowledge correct. We reserve the right to change product design and properties without notice. Since conditions of use are beyond our control users must satisfy themselves that products are suitable for the intended processes and uses. No warranty is given or implied in respect of information or recommendations or that any use of products will not infringe rights belonging to other parties.